



Panasonic Industrial Company

Air Conditioning Department

5KS150FAB21

208 / 230 V, 60 Hz, 1Ø R410A

5KS150FAB21

Application	Cooling (C) / Heating (H)	
Ref. Charge Limit (C & H)	56.4 oz. max.	1600 g. max.
(C)	67.0 oz. max.	1900 g. max.
Refrigerant	R410A	

Rated Performance @ 230 V

Capacity	14,620 BTU/h.
Motor Input	1,535 W
Current	6.70 A
E.E.R.	9.52

Rated ARI Conditions

Evaporating Temp.	45 °F	7.2 °C
Condensing Temp.	130 °F	54.4 °C
Return Gas Temp.	65 °F	18.3 °C
Liquid Temp.	115 °F	46.1 °C
Ambient Temp.	95 °F	35 °C

Compressor Data

Pump Type	Rotary	
Displacement	15.06 cm ³ / rev.	
Oil	FV50S.	
Oil Charge (Precharged)	23.7 fl. oz.	700 cm ³
Net Weight	40.6 lb	18.4 kg.

Maximum Operating Conditions

Evap. Temp. Range	5°F to 66.2°F	-15°C to 19°C
Condensing Temp.	149 °F	65 °C
Return Gas Temp.	95 °F	35 °C
Discharge Gas Temp.	239 °F	115 °C
Motor Wire Temp.	266 °F	130 °C

Motor Data

Motor Type	Permanent Split Capacitor
Locked Rotor Amperes	40 A @ 240 V
Winding Resistance	2.095 Ω (Main), 2.153 Ω (Aux.)
Max. Continuous Current	11.93 A

Electrical Components

Overload Protector	Internal
Run Capacitor	35 μF/ 370 V

*NOTE: If additional torque is required to start the compressor please use a start capacitor and relay. (Ex. when using a TXV.)

Start Capacitor	189 - 227 μF/ 330 V
Relay (GE part number)	3ARR3J5A6

Approval(s)

UL: SA4615

This document sets forth certain operational parameters and conditions for operation of this product. If this product is operated outside of the parameters and conditions stated herein, buyer assume sole and full responsibility and shall indemnify seller with respect to all product failures, and all the consequences thereof. Operation of the product outside of the parameters and conditions specified herein shall serve to invalidate all seller warranties, if any, with respect to the product. Use this document as reference only. For specifications please contact Panasonic's engineering department.

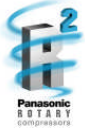

Performance Data @ 230 V, 60 Hz

Temp. Units:	° F
Return Gas	65
Liquid Sub Cooling	15
Ambient (Air Over)	95

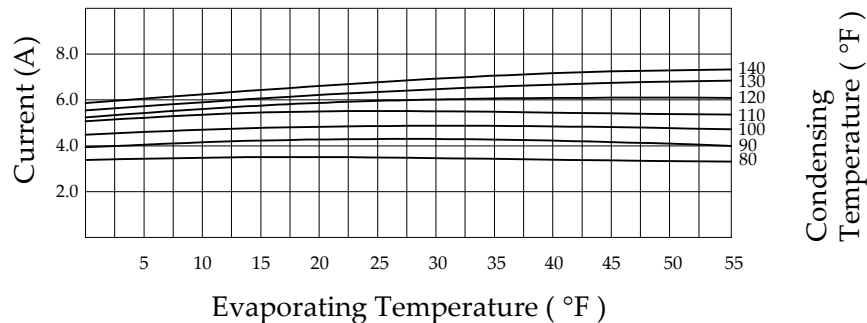
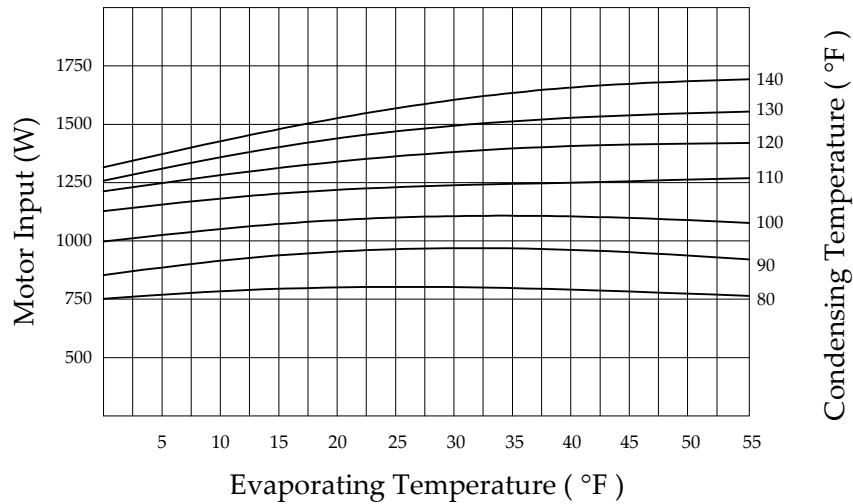
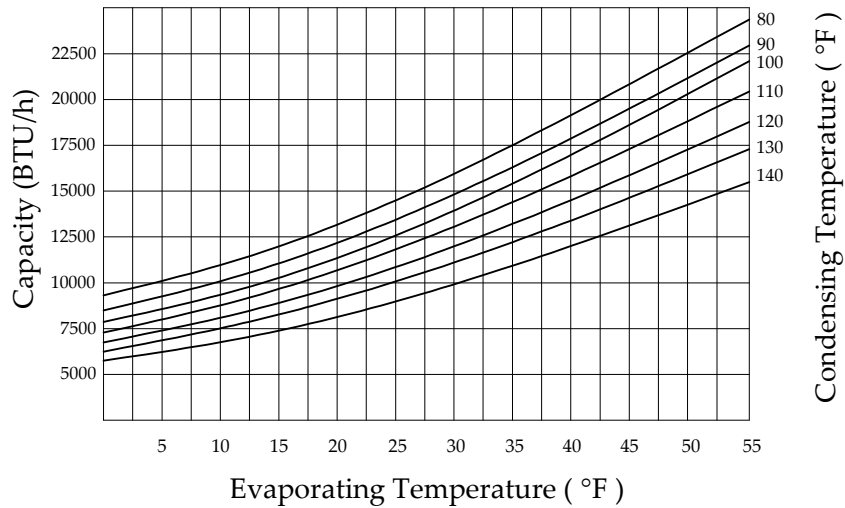

This document sets forth certain operational parameters and conditions for operation of this product. If this product is operated outside of the parameters and conditions stated herein, buyer assume sole and full responsibility and shall indemnify seller with respect to all product failures, and all the consequences thereof. Operation of the product outside of the parameters and conditions specified herein shall serve to invalidate all seller warranties, if any, with respect to the product. Use this document as reference only. For specifications please contact Panasonic's engineering department.

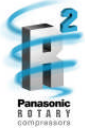

Performance Data @ 230 V, 60 Hz

Temp. Units: ° F
Return Gas 65
Liquid Sub Cooling 15
Ambient (Air Over) 95

Cond. Temp.	80 °F	90 °F	100 °F	110 °F	120 °F	130 °F	140 °F
Evap. Temp.							
5 °F	BTU/h	10070	9200	8645	8005	7365	6830
	Watts	785	900	1025	1130	1235	1305
	Amperes	3.5	3.9	4.6	5.1	5.4	5.5
15 °F	BTU/h	11930	10940	10295	9505	8675	7930
	Watts	805	935	1070	1190	1305	1390
	Amperes	3.6	4.2	4.7	5.3	5.6	6.0
25 °F	BTU/h	14415	13305	12555	11615	10590	9625
	Watts	820	960	1090	1225	1350	1460
	Amperes	3.6	4.3	4.8	5.4	5.9	6.2
35 °F	BTU/h	18090	16835	15970	14845	13580	12350
	Watts	815	965	1105	1250	1385	1505
	Amperes	3.6	4.3	4.8	5.4	6.0	6.4
45 °F	BTU/h	20860	19515	18565	17325	15900	14620
	Watts	785	945	1085	1260	1400	1535
	Amperes	3.5	4.2	4.8	5.4	6.1	6.7
55 °F	BTU/h	25220	23745	22685	21280	19635	17995
	Watts	760	930	1080	1255	1400	1555
	Amperes	3.4	4.1	4.7	5.4	6.1	6.7

Coefficiency

Temp. Units: ° F
Super Heat 20
Sub Cooling 15
Ambient Temp 95

C1 - C10: Coefficiency

S: Evap. Temp. (°F)

D: Cond. Temp. (°F)

Coefficiency	Capacity (BTU/h)	Input (W)	Amps (A)	Mass Flow (lb/h)
C1	19565.90099	137.5685764	-3.904916775	186.5944292
C2	91.70994898	0.812112623	0.022702252	0.241763058
C3	-191.1300117	-0.222956231	0.1264835	-1.681092913
C4	3.550414541	-0.075393282	-0.00038159	0.027447807
C5	1.717886905	-0.002793367	-0.000360459	0.029732963
C6	0.914506803	0.152304422	-0.000479763	0.009985176
C7	-0.012678571	0.000429894	2.6455 E-06	-0.000192301
C8	0.000373087	-0.000404974	-1.84949 E-06	0.000168098
C9	-0.015741497	0.000627551	4.28571 E-06	-0.000205481
C10	-0.001666667	-0.000648148	4.62967 E-07	-1.74965 E-05

Formula

$$X = C1 + C2 * (S) + C3 * D + C4 * (S^2) + C5 * (S * D) + C6 * (D^2) + C7 * (S^3) + C8 * (D * S^2) + C9 * (S * D^2) + C10 * (D^3)$$

This document sets forth certain operational parameters and conditions for operation of this product. If this product is operated outside of the parameters and conditions stated herein, buyer assume sole and full responsibility and shall indemnify seller with respect to all product failures, and all the consequences thereof. Operation of the product outside of the parameters and conditions specified herein shall serve to invalidate all seller warranties, if any, with respect to the product. Use this document as reference only. For specifications please contact Panasonic's engineering department.



WIRING DIAGRAM

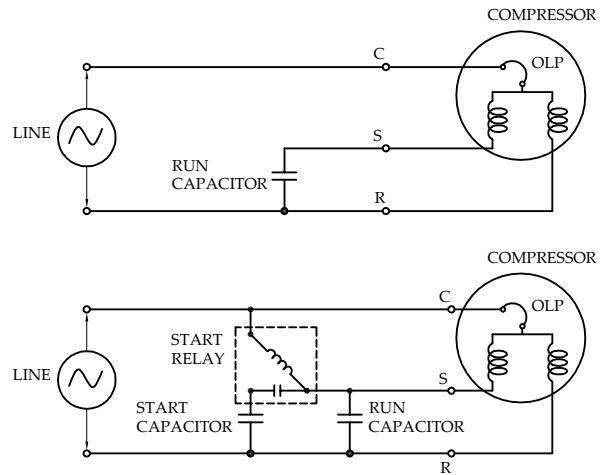
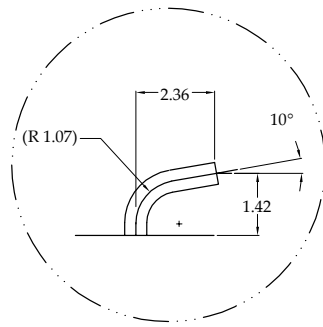
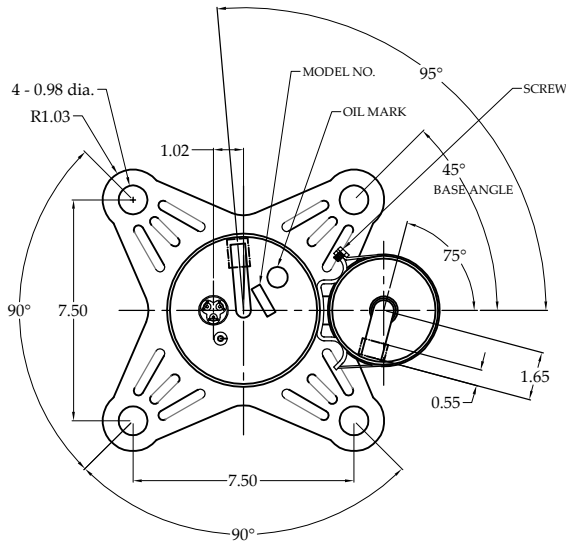

COMPRESSOR ACCESSORIES

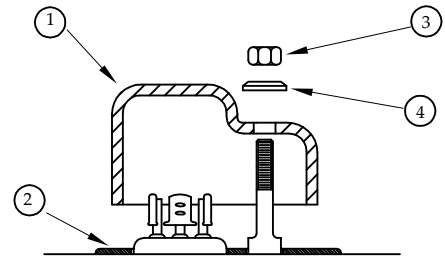

ACCESSORIES	PART NUMBER
-------------	-------------

1	Terminal Cover	7070231U
2	Terminal Cover Gasket	7070632U
3	Nut	7080300
4	Nut Gasket	7070621U
5	Grommet	7070823

COMPRESSOR MOUNTING

