

---

## 6. TROUBLE DIAGNOSIS

---

### 6-1. TROUBLE DIAGNOSIS

---

- As the micom wash machine is configured of the complicate structure, there might be the service call.

Below information is prepared for exact trouble diagnosis and suitable repair guide.

### Caution for the Repair and Replacement

---

Please follow below instruction for the trouble diagnosis and parts replacement.

- 1) As some electronic components are damaged by the charged static electricity from the resin part of wash machine or the human body, prepare the human body earth or remove the poten difference of the human body and wash machine by contacting the power supply plug when work contacting to PCB is executed.

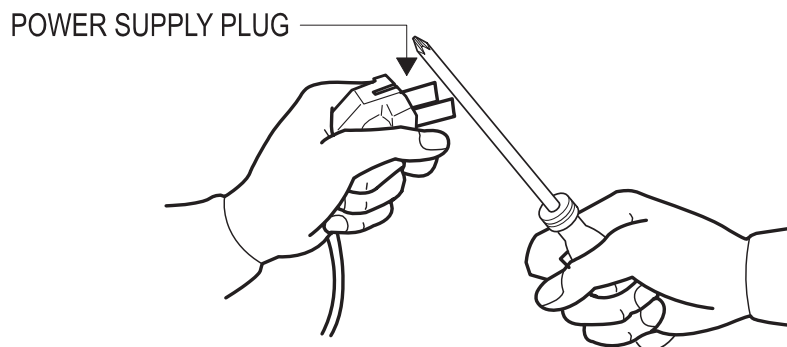

- 2) Since AC 220~240V is applied to the triac T1 and T2 on P.C.B, the electric shock may occur by touching and be careful that the strong and weak electricity are mixed.
- 3) As the P.C.B assembly is designed for no trouble, do not replace the P.C.B assembly by the wrong diagnosis and follow the procedure of the trouble diagnosis when the micom is not operated normally.

No	Item	Cause and treatment
1	The power is not supplied	<ul style="list-style-type: none"> <li>- Is the PCB connector connected well?</li> <li>- Is the voltage normal?</li> <li>- Is the power supply plug connected well?</li> <li>- Is the noise filter connected well?</li> <li>- Is the secondary output of the power supply transformation normal?</li> <li>- Is the fuse disconnected? (option)</li> <li>• If above points are not found, the PCB assembly is out of order. Replace it.</li> </ul>
2	The water is not supplied.	<ul style="list-style-type: none"> <li>- Is the knob open?</li> <li>- Did you push START/PAUSE button after selecting the course?</li> <li>- Is the water supply valve connected well?</li> <li>- Is the winding of the water supply valve continuous?</li> <li>- Is the connection and operation of the pressure switch normal?</li> <li>• If above points are not found, the PCB assembly is out of order. Replace it.</li> </ul>
3	The wash does not start though the water supply is stopped.	<ul style="list-style-type: none"> <li>- Is the connection and operation of the pressure switch normal?</li> <li>- Is the pressure switch hose damaged so that the air is leaked?</li> <li>- Is the pressure switch hose bent?</li> <li>- Check the operation of the water level switch.</li> <li>• If above points are not found, the PCB assembly is out of order. Replace it.</li> </ul>
4	The drum does not rotate during washing.	<ul style="list-style-type: none"> <li>- Is the belt connected well?</li> <li>- Is the winding of the motor continuous? (Rotor winding, stator winding, generator)</li> <li>- Is the motor protector normal?</li> <li>• If above points are not found, the PCB assembly is out of order. Replace it.</li> </ul>
5	The drum rotates by one direction during washing. (The drum rotates to one direction for SPIN.)	<ul style="list-style-type: none"> <li>- The PCB assembly is out of order. Replace it. (Inversion relay open trouble)</li> </ul>
6	Drainage problem.	<ul style="list-style-type: none"> <li>- Is the drainage hose bent?</li> <li>- Is the winding of the drainage pump continuous?</li> <li>- Is the drain filter clogged by the waste?</li> <li>• If above points are not found, the PCB assembly is out of order. Replace it.</li> </ul>
7	Dehydration problem.	<ul style="list-style-type: none"> <li>- The unbalance is detected.</li> <li>- Put in the laundry uniformly and start again.</li> </ul>
8	Abnormal noise during SPIN.	<ul style="list-style-type: none"> <li>- Is the pulley nut loosen?</li> <li>- Is the transport safety device removed?</li> <li>- Is the product installed on the level and stable place? (Little noise may be generated during the high-speed SPIN.)</li> </ul>
9	Leak breaker or current/leak breaker is down during washing.	<p>&lt;When the leak breaker and current breaker is installed separately&gt;</p> <ul style="list-style-type: none"> <li>- When the leak breaker is down, check and make the earth of the outlet.</li> <li>- When the current is down, the current is leaked.</li> </ul> <p>&lt;Is the breaker down when the leak/current breaker is combined?&gt;</p> <ul style="list-style-type: none"> <li>- Check the rated capacity of the current and leak breaker. The current breaker may be down due to the lack of the current when the wash machine and other apparatus are used. In this case, execute the cold water wash to check whether the current capacity is lack.</li> </ul>

## 6-2. PROBLEM CHECKING AND METHOD OF PCB

### 6-2-1. The Part Of Power Source

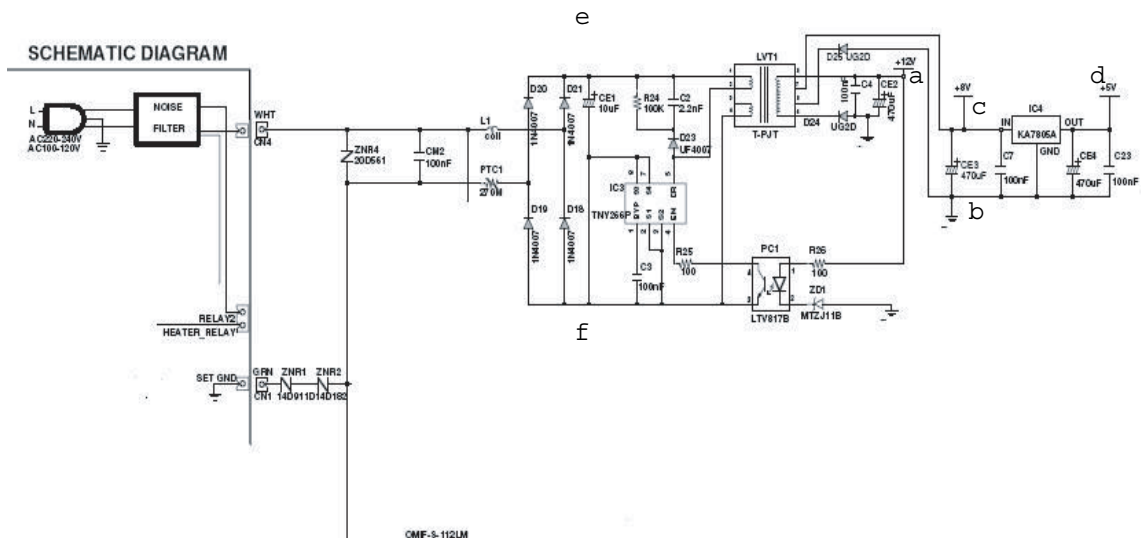
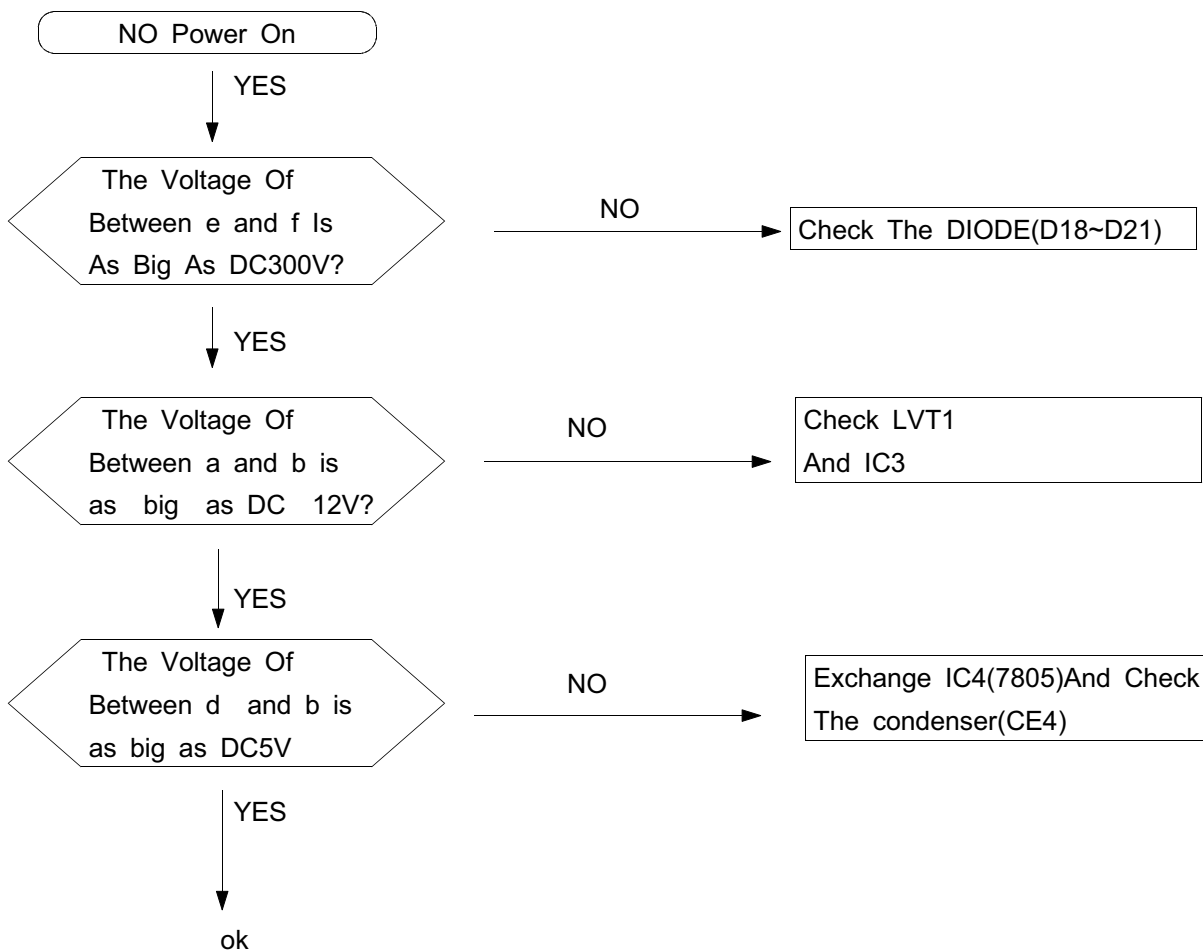

### 6-2-2. Reset Part

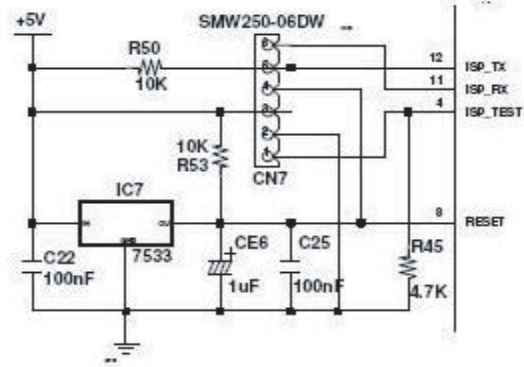
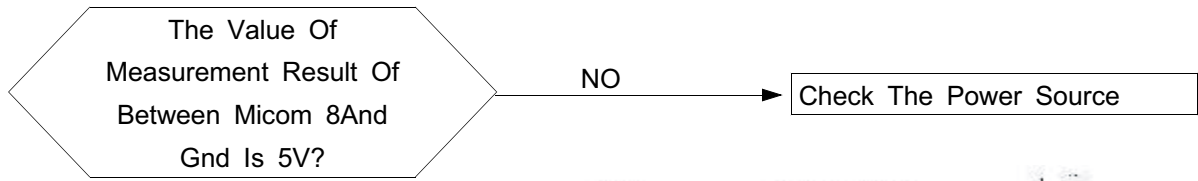

### 6-2-3. Interrupt Part

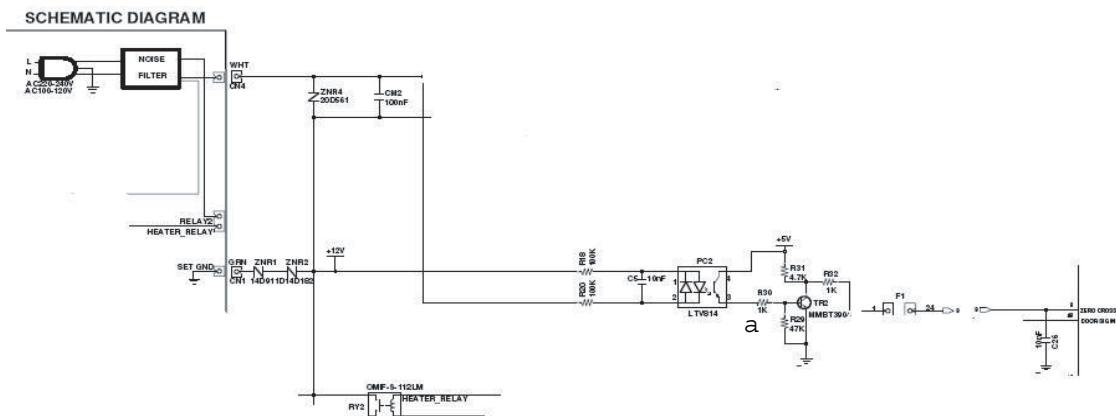
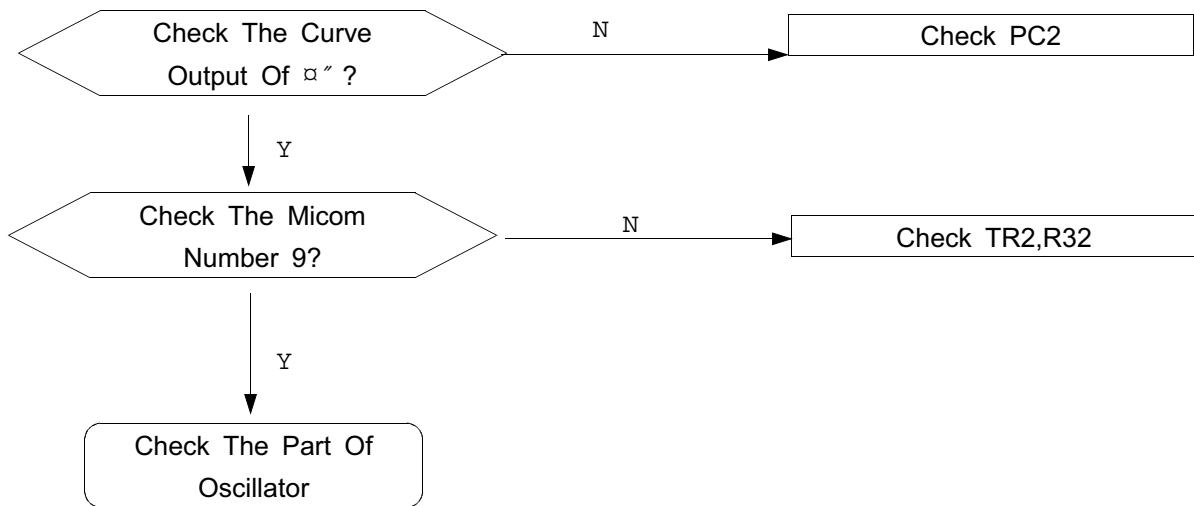

6-2-4. Checking The Part Of An Oscillator

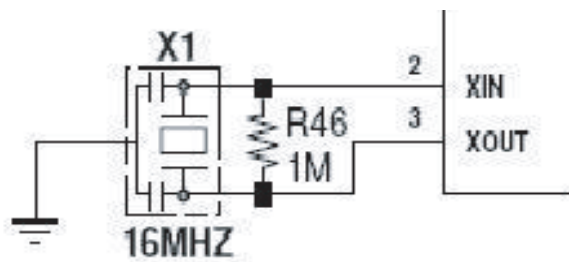
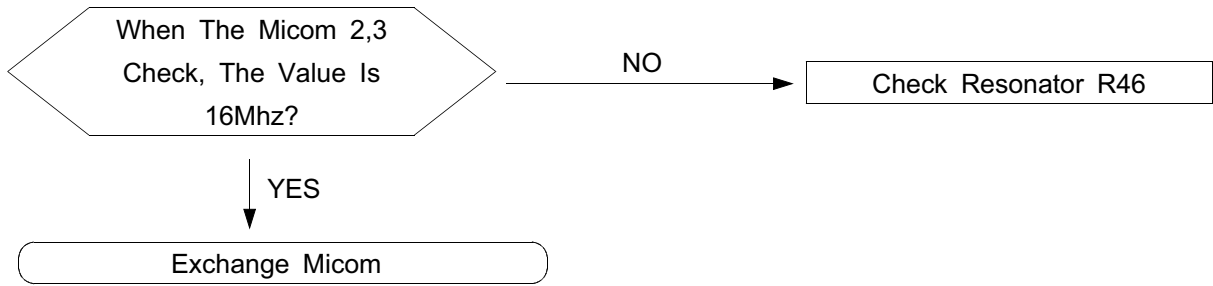

6-2-5. Check The Part Of Buzzer

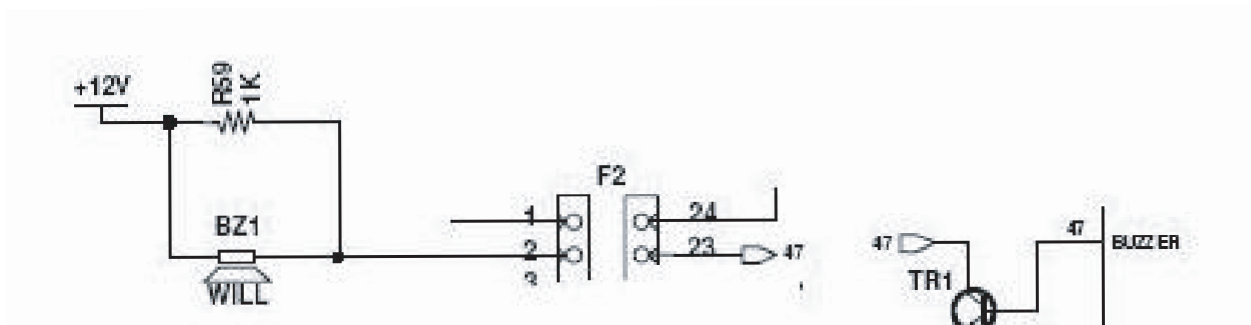
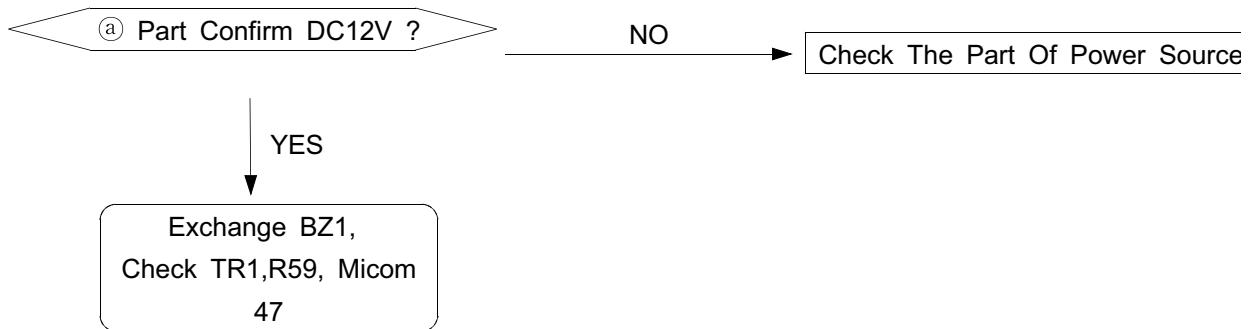

## 6-2-6. Driving Part Checking

- ◆ Confirm The Output Of DC5V, When The Every Part Of Micom Number Check, According To The Some Problem Condition  
ex) When The Drain Is Not Operating But Pump Motor Is Operating, Check The 5Voltage Of Micom

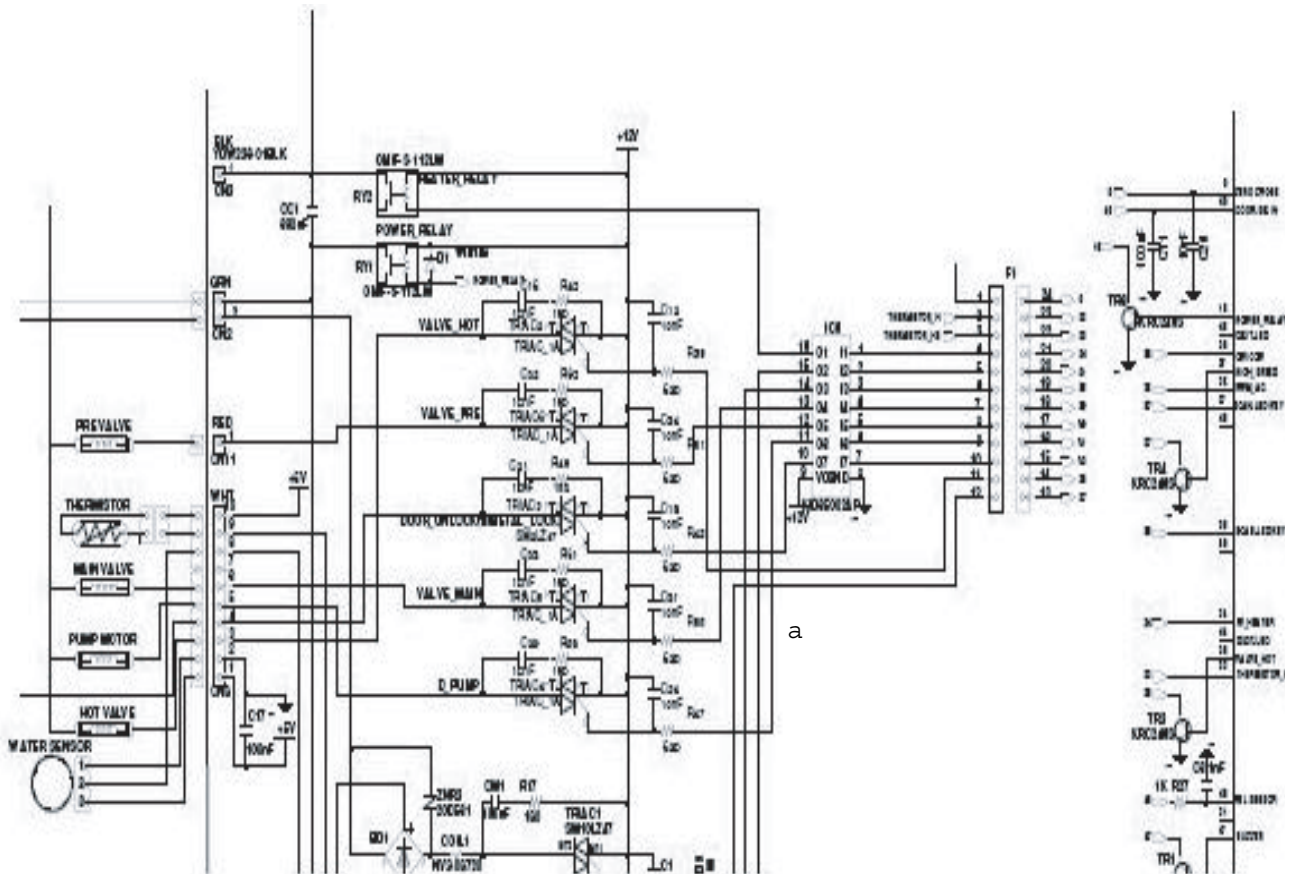
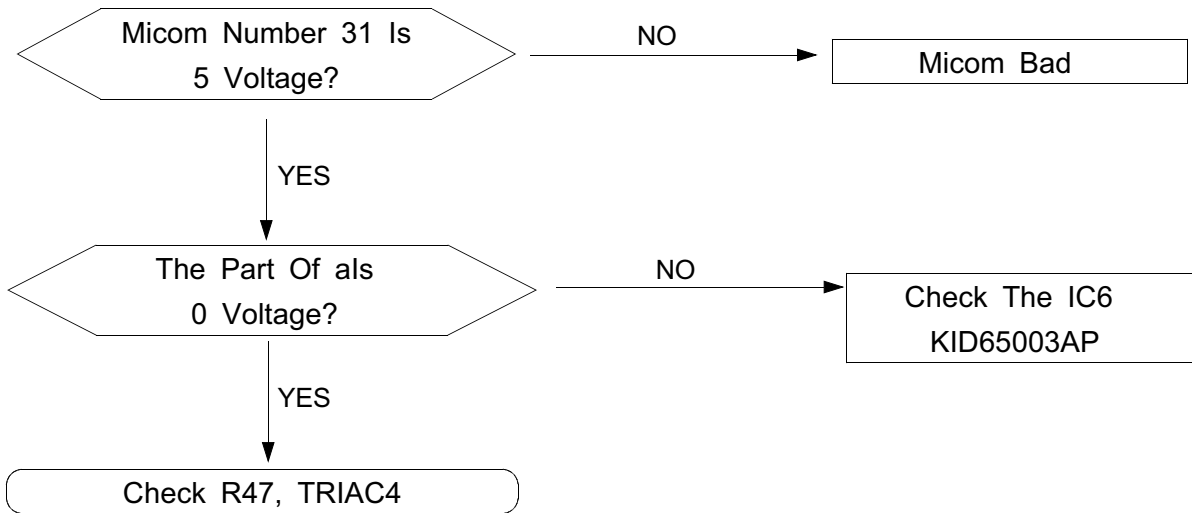

※ Check The Micom 18th In The Above Method When The Cold Water Is Bad

6-2-7. Confirm The Driving Part Of Motor

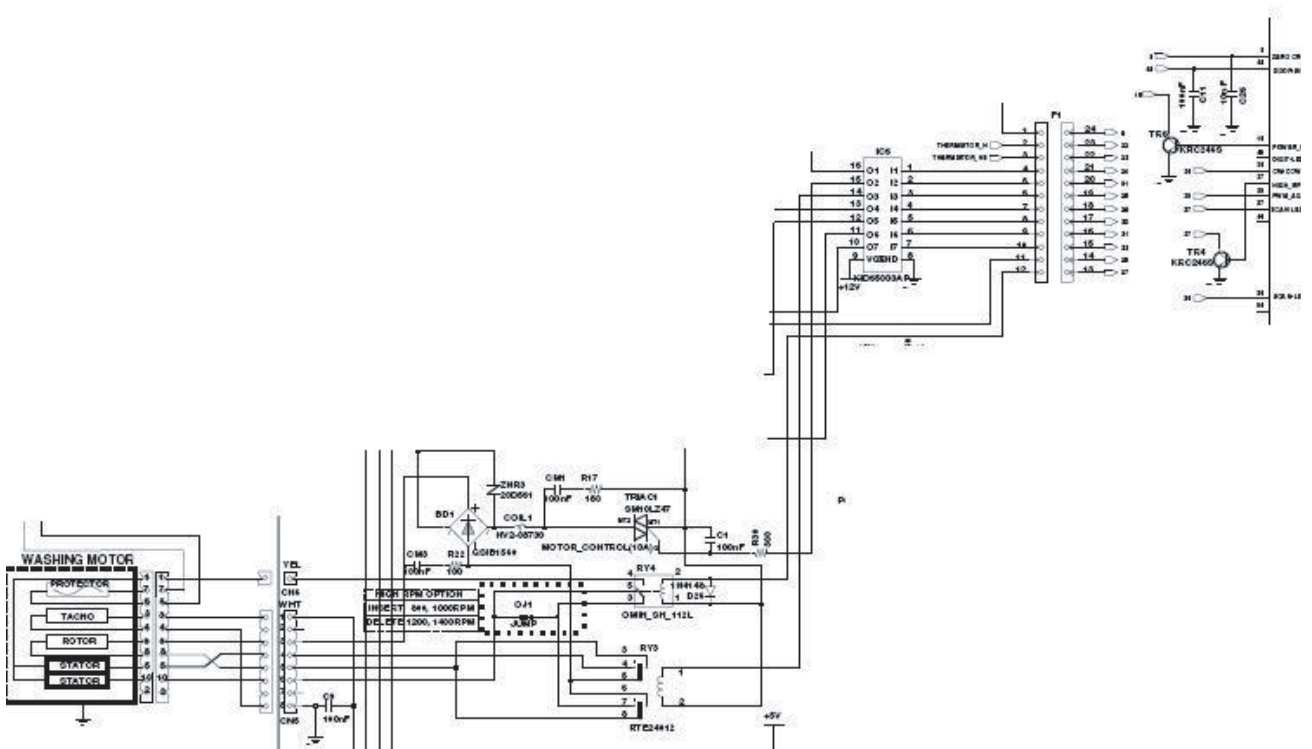
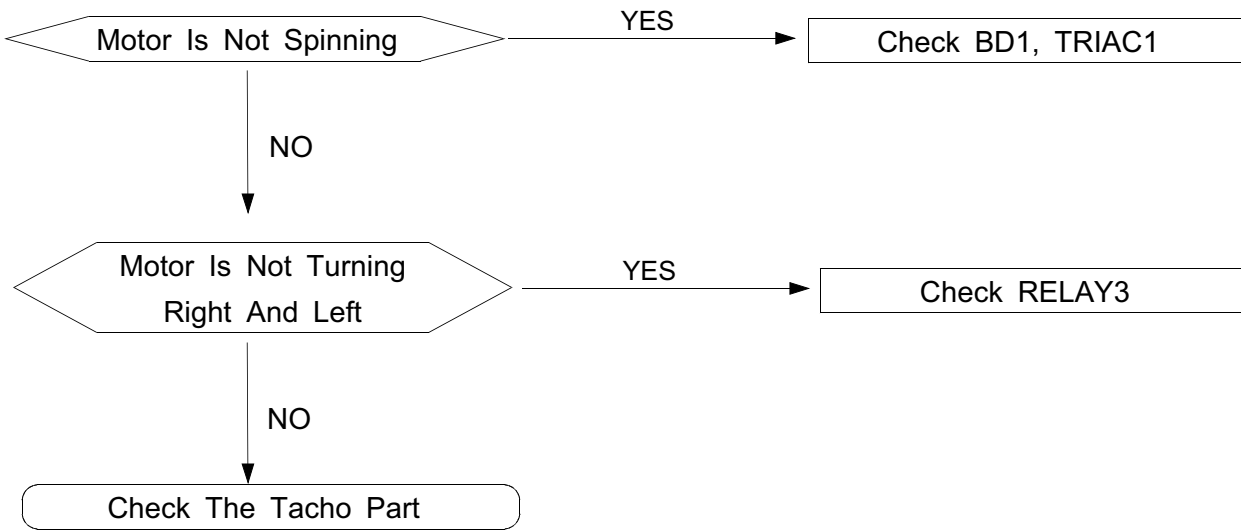

---

6-2-8. Checking The Tacho Part

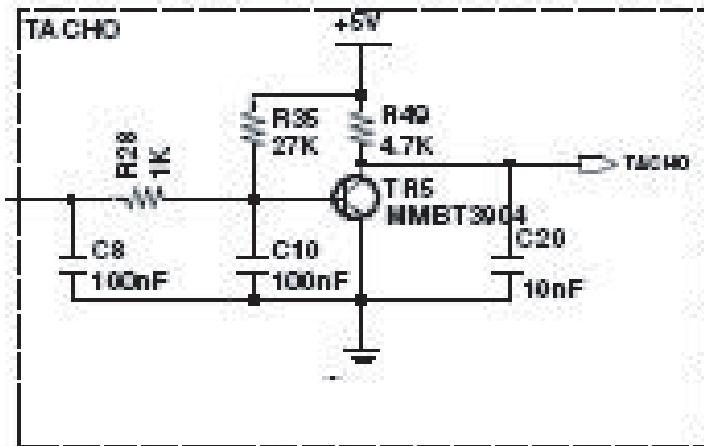
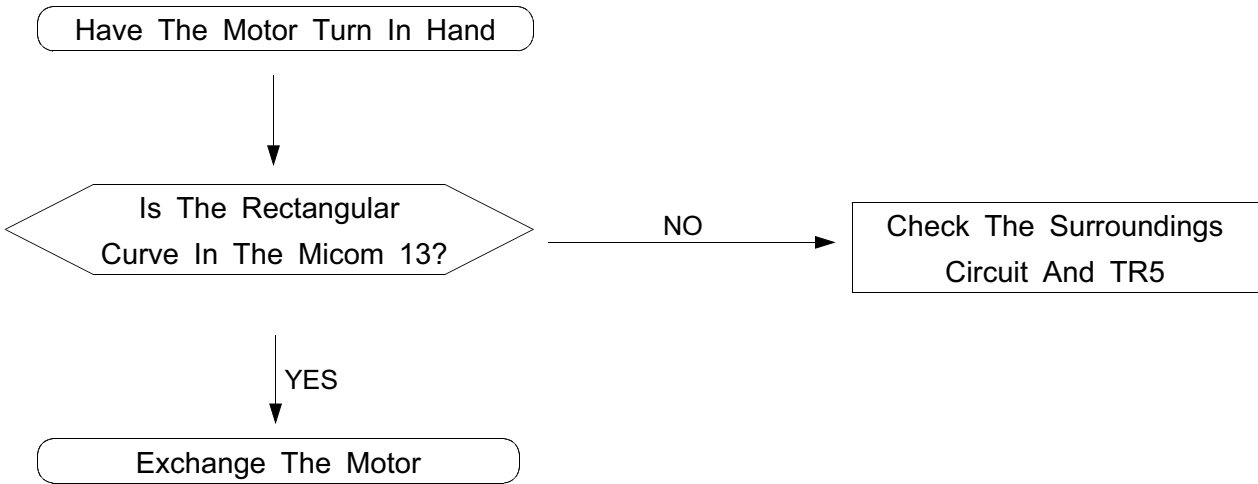



### 6-3. DETAILED DIAGNOSIS

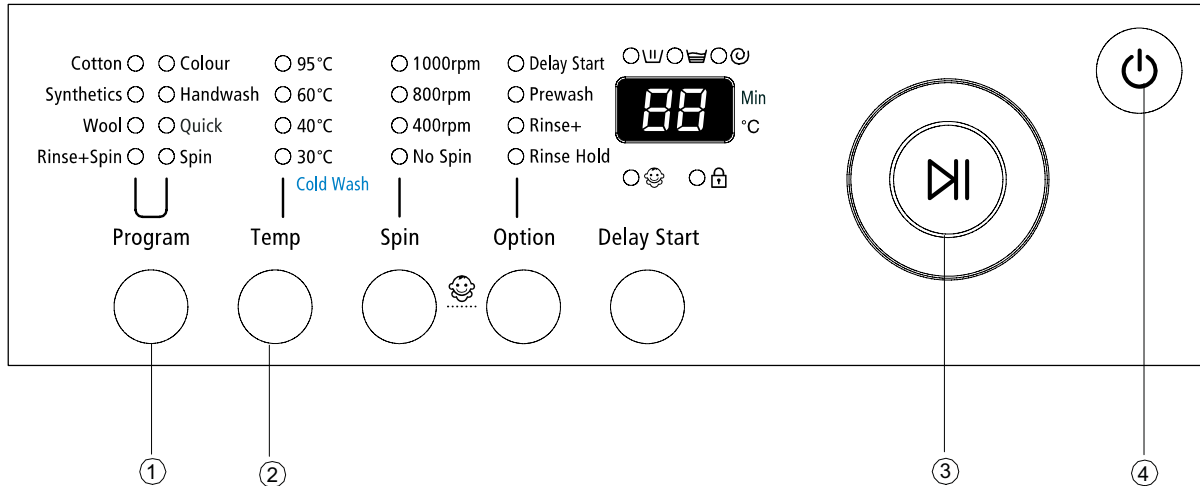

#### 1. Driving Compartment Test Mode

- A. Hold down the ① and the ② buttons simultaneously and then press the Power button ④. (All of the LEDs light up and the display shows t1 in 3 seconds.)
- B. The driving part can be tested when you press the push button dial ③ right after entering into the TEST MODE.

No	Check	Test Method	Description
1	Motor	Check if the motor operates or check the Motor terminals.	Motor Wiring (Red/White①/Blue/Pink/Violet/White②) Resistance between Blue-Red, Red-White① and White①-Blue should be $2.0\Omega \pm 10\%$ .
2	Water Valve	Check if it supplies water or check the Water Valve terminals.	Check resistance of the Water Valve terminals.
3	Drain Pump	Check if it drains normally or check the pump terminals.	Check resistance of the Drain Pump terminals.
4	Door S/W	Check if it works at the Cotton course or check the Door S/W terminals.	Check resistance of the Door S/W terminals.
5	Water Pressure Sensor	Refer to Page 15. (Water Level Table at each Course)	Check frequency (Hz) between the Water Pressure Sensor terminals.
6	MAIN PCB	1. Press the buttons on the display. Check if all of the LEDs work. 2. Check if voltage between the white and the black terminals is 220~240V.	1. Replace the SUB PCB. 2. If not, replace the Noise Filter.