

# 12 . Illustrated Parts Catalog.

## 12-1) Freezer Room Exploded View

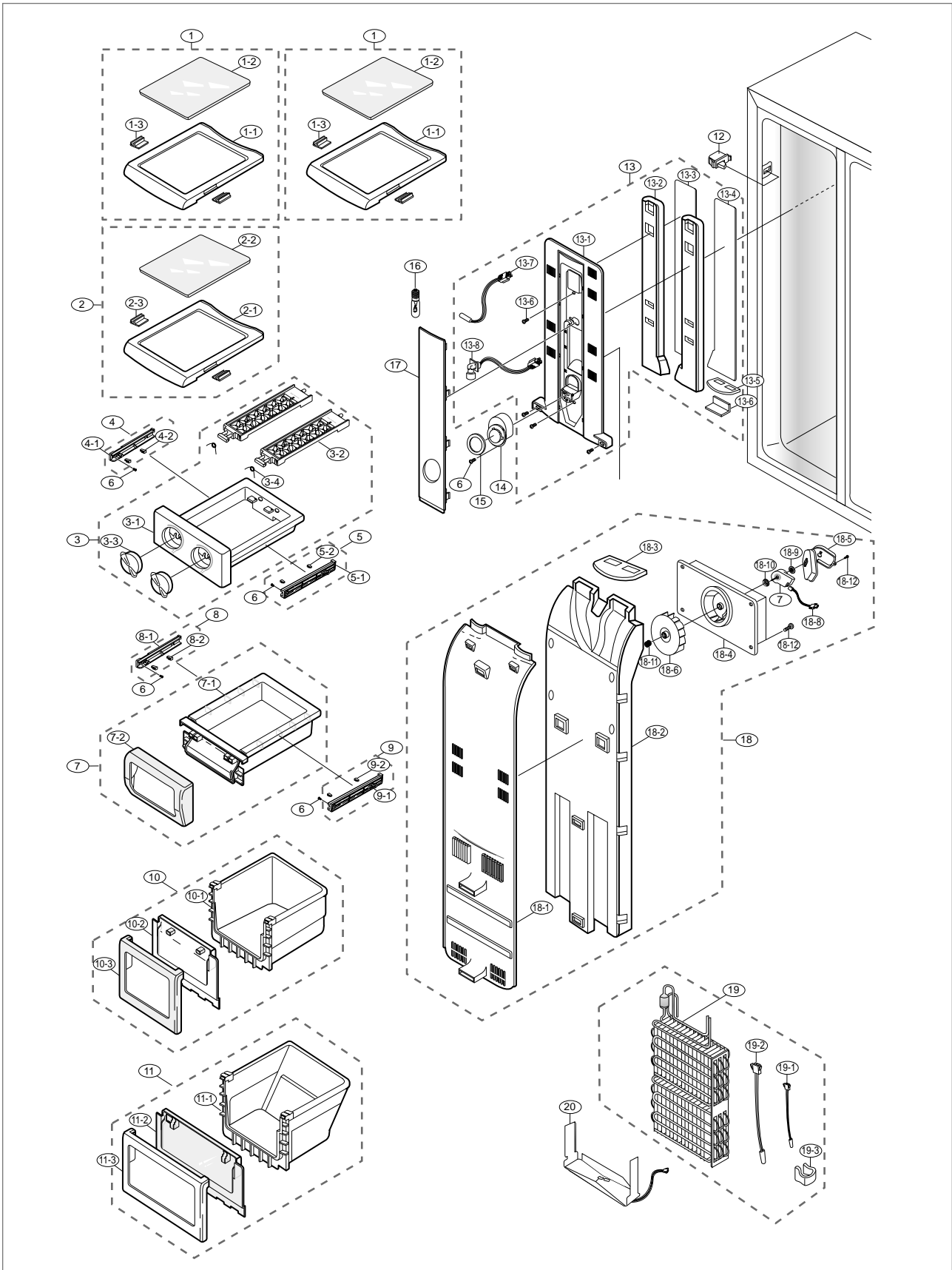

## Illustrated Parts Catalog.

### ■ Parts List of Freezer

NO	CODE-NO	PART NAME	Spec	Quantity	Remark
1	DA67-00180A	SHELF-FRE ASSY	GLASS-SHELF	1	
1-1	DA67-00175A	SHELF-FRE	HIPS	1	
1-2	DA67-00177B	SHELF GLASS	GLASS	1	
1-3	DA64-00090A	TRIM-SHELF	PVC	2	
2	DA67-00181A	SHELF-FRE ASSY	GLASS-SHELF	1	
2-1	DA67-00146A	SHELF-FRE	HIPS	1	
2-2	DA67-00177C	SHELF GLASS	GLASS	1	
2-3	DA64-00090A	TRIM-SHELF	PVC	2	
3	DA66-00047A	TRAY-ICE ASSY		1	
3-1	DA71-00059A	FIXER-TRAY ICE	HIPS	1	
3-2	DA66-00032A	TRAY-ICE	HIPS	2	
3-3	DA64-00084A	KNOB-TRAY ICE	HIPS	2	
3-4	DA61-20136A	SPRING ETC-ICE MAKER	STS304 , P110	2	
4	DA97-01292A	ASSY RAIL-BASKET,L	HIPS	2	
4-1	DA61-00044B	RAIL-BASKET,L	HIPS	1	
4-2	DA63-00202A	GROMMET-RAIL	NY-6	1	
5	DA97-01291A	ASSY RAIL-BASKET,R	HIPS	2	
5-1	DA61-00045B	RAIL-BASKET,R	HIPS	1	
5-2	DA63-00202A	GROMMET-RAIL	NY-6	1	
6	6002-000215	SCREW-TAPPING	TH,+1,M4.0,L16,ZPC(YEL)		
7	DA67-00186A	CASE-ICE CUBE ASSY	HIPS	1	
7-1	DA67-00155A	CASE-TRAY ICE	GPPS	1	
7-2	DA63-00179A	COVER-TRAY	HIPS	1	
8	DA97-01247A	ASSY RAIL LOW,L	HIPS	1	
8-1	DA61-60179A	RAIL-LOW	GPPS	1	
8-2	DA63-40256B	GROMMET-RAIL	NY-6	1	
9	DA97-01248A	ASSY RAIL LOW,R	HIPS	1	
9-1	DA61-60180A	RAIL-LOW	HIPS	1	
9-2	DA63-40256B	GROMMET-RAIL	NY-6	1	
10	DA67-00182C	CASE-BASKET UPP ASSY		1	
10-1	DA67-00150A	CASE-BASKET	PP	1	
10-2	DA63-00174C	COVER-FRONT FRE,B	GPPS	1	
10-3	DA63-00170A	COVER-FRONT	HIPS	1	
11	DA67-00183C	CASE-BASKET LOW ASSY		1	
11-1	DA67-00151A	CASE-BASKET	PP	1	
11-2	DA63-00174C	COVER-FRONT FRE,B	GPPS	1	
11-3	DA63-00170A	COVER-FRONT	HIPS	1	
12	DA34-10121A	SWITCH-DOOR	PA6	1	
13	DA97-00101J	ASSY COVER-MULTI FRE		1	
13-1	DA63-00363A	COVER EVAP-FRE,FRONT UPP	UPP PP	1	
13-2	DA72-00245A	INSULATION DUCT-FRE,UPP	FOAM-PS	1	
13-3	DA72-00158F	SEAL EVAP-FRONT FRE,L	T2.0	1	
13-4	DA72-00159E	SEAL EVAP-FRONT,FRE R	T2.0	1	
13-5	DA62-00219A	SEAL-AIR FRE,UPP	OJC-3000 , T7	1	
13-6	DA70-00215B	PLATE-INS,DUCT	RD-PVC , T1.2	2	
13-7	DA32-10105H	SENSOR-ASSY	502AT, -10~35 , 5V	1	
14	DA63-00178A	COVER-SENSOR	GPPS	2	
15	DA63-00162B	COVER SENSOR-B	ABS , PNC2	2	
16	4713-001132	LAMP-INCANDESCENT	240V , 30W	3	



# 12 . Illustrated Parts Catalog.

## 12-2) Refrigerator Room Exploded View (RS21N, RS21H, RS21D, RS21F, RS23N, RS23H, RS23D, RS23F)

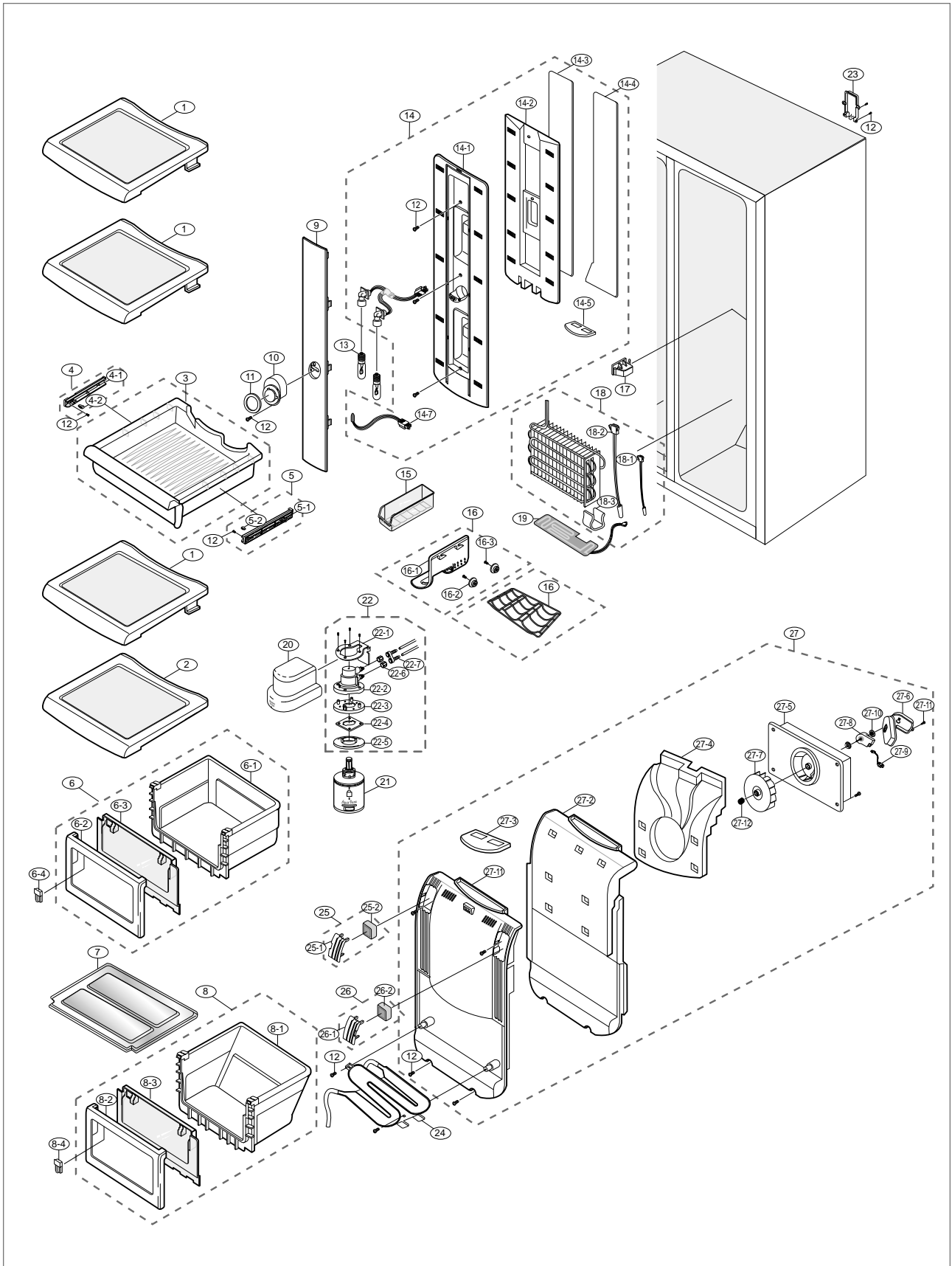

## Illustrated Parts Catalog.

### ■ Parts List of Refrigerator

NO	CODE-NO	PART NAME	Spec	Quantity	Remark
1	DA67-00149A	SHELF-REF UPP	GLASS	1	
2	DA67-00148B	SHELF REF-LOW	GLASS	1	
3	DA66-00038A	TRAY-CHIL ROOM	GPPS	1	
4	DA97-01247A	ASSY RAIL LOW,L	HIPS	1	
4-1	DA61-60179A	RAIL-LOW	HIPS	1	
4-2	DA63-40256B	GROMMET-RAIL	NY-6	1	
5	DA97-01248A	ASSY RAIL LOW,R	HIPS	1	
5-1	DA61-60180A	RAIL-LOW	HIPS	1	
5-2	DA63-40256B	GROMMET-RAIL	NY-6	1	
6	DA67-00184C	CASE-VEG UPP ASSY	HIPS	1	
6-1	DA63-00175A	COVER-FRONT	HIPS	1	
6-2	DA63-00177C	COVER-FRONT REF,B	GPPS	1	
6-3	DA67-00152A	CASE-VEG	PP	1	
6-4	DA64-00085A	KNOB-MOIS CONT	ABS	1	
7	DA63-10942B	COVER-VEG,LOW	HIPS	2	
8	DA67-00185C	CASE-VEG LOW ASSY	HIPS	1	
8-1	DA63-00175A	COVER-FRONT	HIPS	1	
8-2	DA63-00177C	COVER-FRONT REF,B	GPPS	1	
8-3	DA67-00153A	CASE-VEG	PP	1	
8-4	DA64-00085A	KNOB-MOIS CONT	ABS	1	
9	DA63-01638A	COVER-LAMP REF	PP	1	
10	DA63-00178A	COVER-SENSOR	GPPS	2	
11	DA63-00162B	COVER SENSOR-B	ABS , PNC2	2	
12	6002-000215	SCREW-TAPPING	TH,+1,M4.0,L16,ZPC(YEL)	15	
13	4713-001132	LAMP-INCANDESCENT	240V , 30W	3	
14	DA97-01420A	ASSY COVER-MULTI REF		1	
14-1	DA63-00158A	COVER-MULTI	PP	1	
14-2	DA72-00144A	INSULATION	FOAM-PS	1	
14-3	DA62-00566A	SEAL-MULTI REAR,L	T2.0	1	
14-4	DA62-00566B	SEAL-MULTI REAR,R	T2.0	1	
14-5	DA62-00587A	SEAL-MULTI AL,UPP	FOAM-PE + AL50um	1	
14-6	DA47-00025H	LAMP HOLDER	E 14,250V,1A,370,NTR,PBT 5VA	1	
14-7	DA32-10105H	SENSOR-ASSY	502AT,K-PJT,-10~35,5V,5KOHM	1	
15	DA67-40250E	TRAY-UTILITY	GPPS	1	
16	DA67-00711A	SHELF WIRE-WINE,RACK	MSWR10	1	
16	DA67-00145A	SHELF-WINE	HIPS		
16-1	DA71-20252A	FIXER-GROMMET DOOR	ABS	2	
17	DA34-10110B	SWITCH-DOOR	125/1.5A	1	
18	DA96-00013H	ASSY EVAP-REF	230V , 110W	1	
18-1	DA32-00006B	SENSOR ASSY	PX-41C RD SEN,A TOP,-10°C	1	
18-2	DA47-10148J	THERMO FUSE-ASSY	SW-102T,250V	1	
18-3	DA61-00453A	FIXER-SENSOR	PP	1	
19	DA47-00039B	HEATER-DRAIN ASSY,REF	240V	1	
19-1	DA47-00038B	HEATER-DRAIN,REF	240V	1	
19-2	DA70-00231A	PLATE-DRAIN,REF	SBHG1 , T0.6	1	
20	DA97-00724A	ASSY-COVER FILTER	ABS	1	
21	DA29-00003A	FILTER-WATER ASS'Y		1	
22	DA97-00725C	ASSY CASE-FILTER	A-TOP,EXP,INSERT-FILTER	1	
23	DA63-00586A	COVER-TUBE FILTER	PP	1	



# 12 . Illustrated Parts Catalog.

## 12-3) Refrigerator Room Exploded View (RS21J, RS21K, RS23J, RS23K)

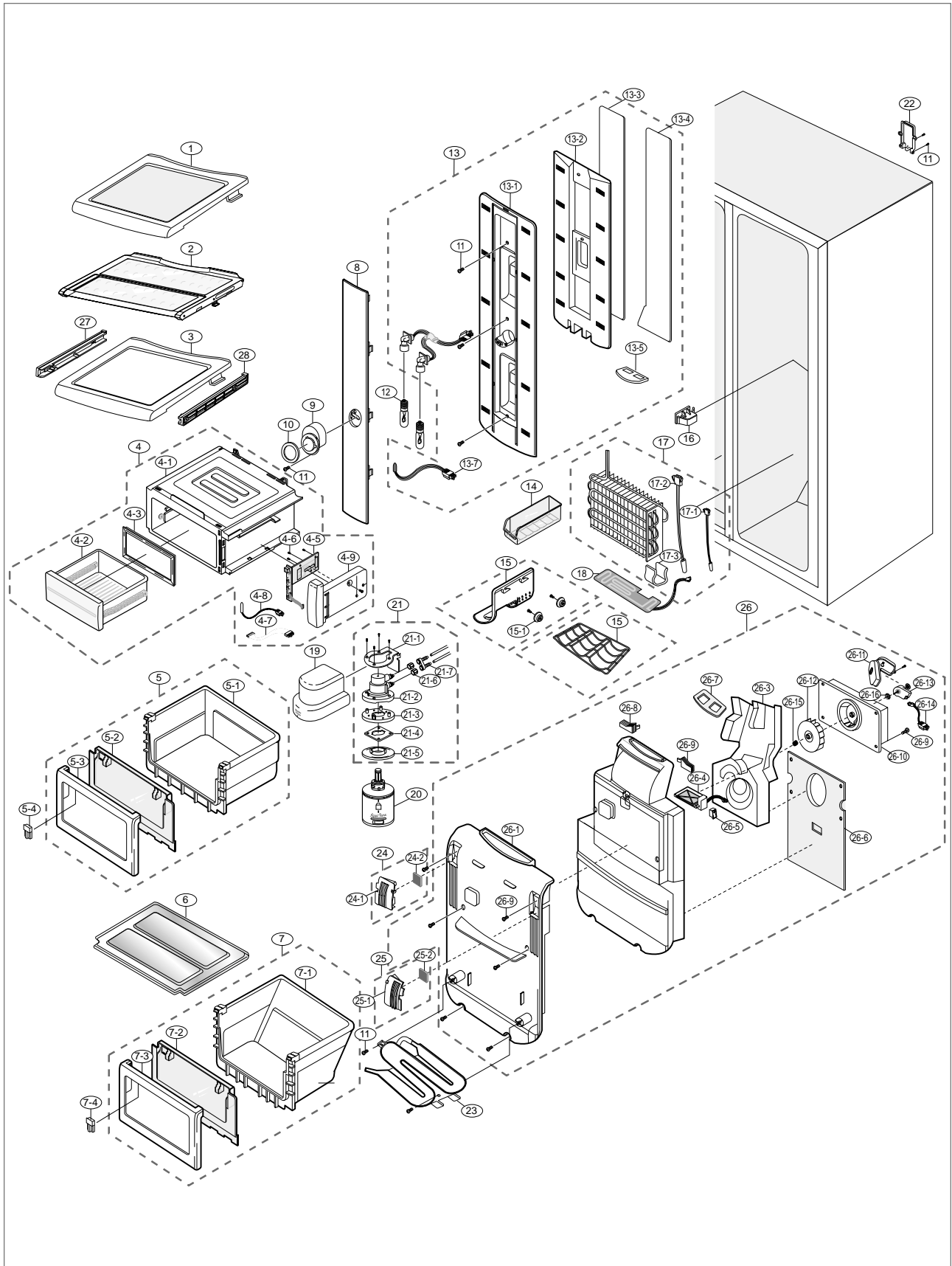

## Illustrated Parts Catalog.

### ■ Parts List of Refrigerator

NO	CODE-NO	PART NAME	Spec	Quantity	Remark
1	DA67-00149A	SHELF-REF UPP	GLASS	1	
2	DA97-00199L	ASSY SHELF-FOLD	GLASS	1	
3	DA97-01454A	ASSY SHELF REF-LOW	HIPS	1	
4	DA97-01413A	ASSY CASE-CONVERTIBLE	CONVERTIBLE	1	
4-1	DA97-01412A	ASSY CASE-	SUB CONVERTIBLE	1	
4-2	DA97-01411A	CONVERTIBLE,	CONVERTIBLE	1	
4-3	DA63-01783A	ASSY TRAY-CONVERTIBLE	SF-PVC	1	
4-4	DA61-01207A	GASKET-CONVERTIBLE	ABS-SCRAP	1	
4-5	DA41-00108A	CASE-CONTROL CONV	CONVERTIBLE	1	
4-6	6002-000462	PBA SUB	PH,+2,M3.0,L10,ZPC(YEL),M	5	
4-7	DA39-00215A	SCREW-TAPPING		1	
4-8	DA32-10109X	WIRE HARNESS	5V , CONVERTIBLE	1	
4-9	6009-001293	SENSOR ASSY	STS304,-,PWH,+M4,L15.5	2	
5	DA67-00184C	SCREW-SPECIAL		1	
5-1	DA63-00175A	CASE-VEG UPP ASSY	HIPS	1	
5-2	DA63-00177C	COVER-FRONT	GPPS	1	
5-2	DA67-00152A	COVER-FRONT REF,B	PP	1	
5-4	DA64-00085A	CASE-VEG	ABS	1	
6	DA63-10942B	KNOB-MOIS CONT	HIPS	2	
7	DA67-00185C	COVER-VEG,LOW	GPPS	1	
7-1	DA63-00175A	CASE-VEG LOW ASSY	PP	1	
7-2	DA63-00177C	COVER-FRONT	ABS	1	
7-3	DA67-00153A	COVER-FRONT REF,B	PP	1	
7-4	DA64-00085A	CASE-VEG	ABS	1	
8	DA63-01638A	KNOB-MOIS CONT	PP	1	
9	DA63-00178A	COVER-LAMP REF	GPPS	2	
10	DA63-00162B	COVER-SENSOR	ABS , PNC2	2	
11	6002-000215	COVER SENSOR-B	TH,+1,M4.0,L16,ZPC(YEL)	15	
12	4713-001132	SCREW-TAPPING	240V , 30W	3	
13	DA97-01420A	LAMP-INCANDESCENT		1	
13-1	DA63-00158A	ASSY COVER-MULTI REF	PP	1	
13-2	DA72-00144A	COVER-MULTI	FOAM-PE	1	
13-3	DA62-00566A	INSULATION	T2.0	1	
13-4	DA62-00566B	SEAL-MULTI REAR,L	T2.0	1	
13-5	DA62-00587A	SEAL-MULTI REAR,R	POAM-PE	1	
13-6	DA47-00025H	SEAL-MULTI AL,UPP	E 14,250V,1A,370,NTR,PBT 5VA	1	
13-7	DA32-10105H	LAMP HOLDER	502AT,K-PJT,-10~35,5V,5KOHM	1	
14	DA67-40250E	SENSOR-ASSY	GPPS	1	
15	DA67-00711A	TRAY-UTILITY	MSWR10	1	
15	DA67-00145A	SHELF WIRE-WINE,RACK	HIPS		
15-1	DA71-20252A	SHELF-WINE	ABS	2	
16	DA34-10110B	FIXER-GROMMET DOOR	-,125/1.5A.25,-,-,WHT,-,-	1	
17	DA96-00013H	SWITCH-DOOR	230V , 110W	1	
17-1	DA32-00006B	ASSY EVAP-REF	PX-41C RD SEN , -10°C ~	1	
17-2	DA47-10148J	SENSOR ASSY	SW-102T,250V	1	
17-3	DA61-00453A	THERMO FUSE-ASSY	PP	1	
18	DA47-00039B	FIXER-SENSOR	240V	1	
18-1	DA47-00038B	HEATER-DRAIN ASSY,REF	240V	1	
18-2	DA70-00231A	HEATER-DRAIN,REF	SBHG1 , T0.6	1	



# Illustrated Parts Catalog.

## ■ Parts List of Refrigerator

NO	CODE-NO	PART NAME	Spec	Quantity	Remark
19	DA97-00724A	ASSY-COVER FILTER		1	
20	DA29-00003A	FILTER-WATER ASS'Y		1	
21	DA97-00725C	ASSY CASE-FILTER		1	
22	DA63-00586A	COVER-TUBE FILTER	PP	1	
23	DA74-00056F	TANK WATER-ASSY	HD-PE	1	
24	DA63-00365C	ASSY-COVER PURIFIER,L		1	
24-1	DA63-00163A	COVER-PURIFIER L	ABS		
24-2	DA02-90106K	CATALYST-LTC	SS400-10-3		
25	DA63-00366C	ASSY-COVER PURIFIER,R		1	
25-1	DA63-01643A	COVER-PURIFIER R	ABS		
25-2	DA02-90106K	CATALYST-LTC	SS400-10-3		
26	DA97-01419A	ASSY COVER-EVAP REF		1	
26-1	DA63-01636A	COVER-EVAP REF	PP	1	
26-2	DA62-00505A	INSULATION DUCT-REF,A	FOAM-PS	1	
26-3	DA62-00506A	INSULATION DUCT-REF,B	FOAM-PS	1	
26-4	DA31-00043A	MOTOR-DAMPER	NSBA001TA1,AT-PJT,MAX 60MA	1	
26-5	DA61-00413A	FIXER-AIR GUIDE	PP	1	
26-6	DA62-00567A	SEAL-COVER EVAP	FOAM-PE + AL(30um)	1	
26-7	DA62-00568A	SEAL-AIR REF,UPP	OJC-3000 , T5	1	
26-8	DA62-00614A	SEAL CUTT FOAM,LEX	SPONGE , T5	1	
26-9	6002-000215	SCREW-TAPPING	TH,+,1,M4.0,L16,ZPC(YEL),M	4	
26-10	DA61-00417A	CASE MOTOR	ABS-SCRAP	1	
26-11	DA63-00713A	COVER-MOTOR	PP	1	
26-12	DA31-00016A	FAN-CIRCUIT		1	
26-13	DA31-00020J	MOTOR DC-BLDC(SENSOR)	DREP3020LB,AT(F,R)	1	
26-14	DA39-00060B	WIRE HARNESS-MOTOR		1	
26-15	DA61-20128A	SPRING ETC-FAN	STS27 , PI7.8 ,ID1.0	1	
26-16	DA63-00423A	GROMMET-MOTOR,BLDC	NBR	2	
27	DA61-01205A	SUPPORT-SHELF REF,L	HIPS	1	
28	DA61-01206A	SUPPORT-SHELF REF,R	HIPS	1	

# 12 . Illustrated Parts Catalog.

## 12-4) Unit Exploded View (RS21N, RS21H, RS21D, RS21F, RS23N, RS23H, RS23D, RS23F)

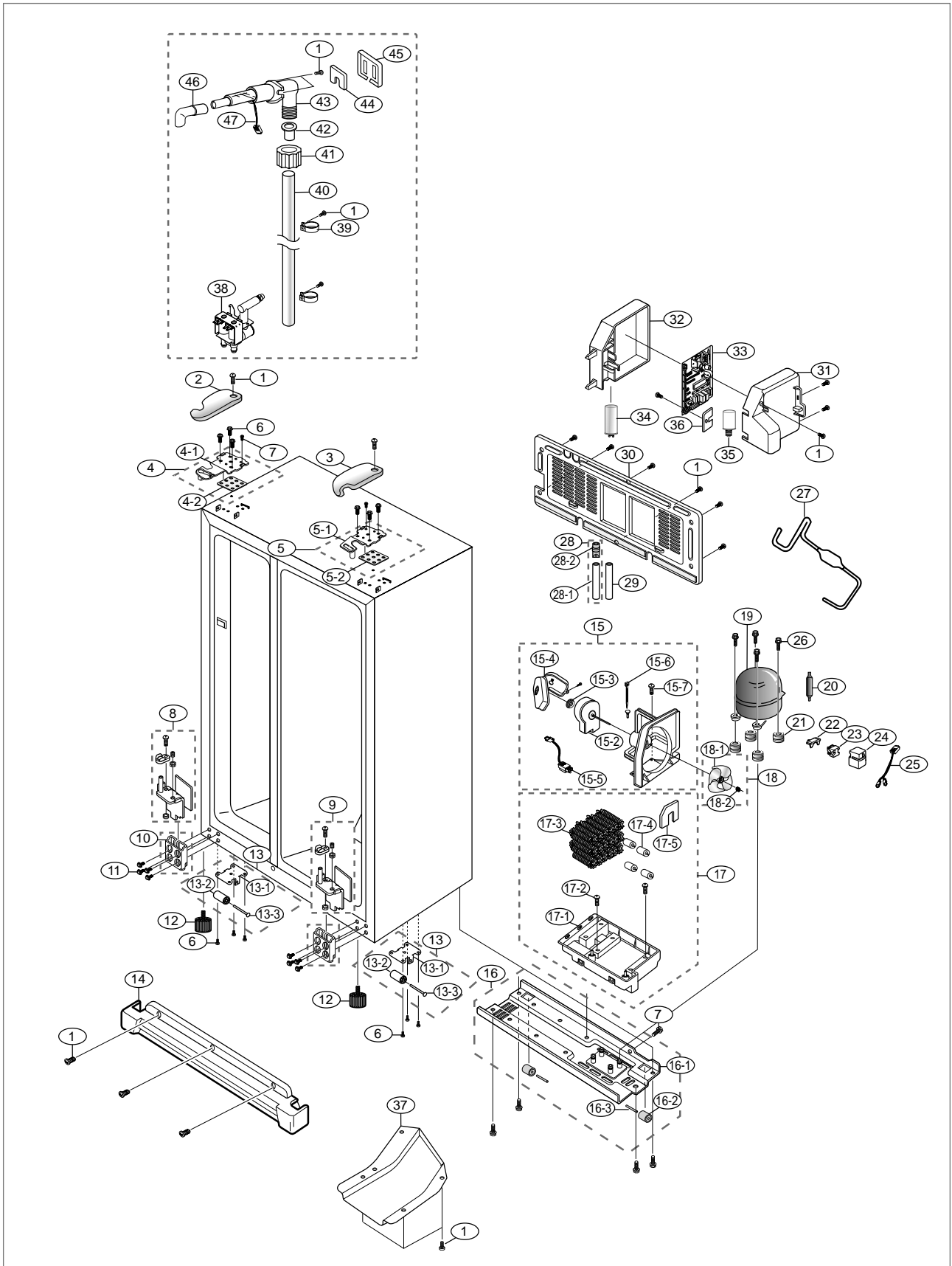

## Illustrated Parts Catalog.

### ■ Parts List of Unit Exploded View

NO	CODE-NO	PART NAME	Spec	Quantity	Remark
1	6002-000213	SCREW-TAPPING	TH,+,1,M4,L12,ZPC(YEL)	12	
2	DA63-01379B	COVER HINGE-UPP,L	ABS	1	
3	DA63-01380B	COVER HINGE-UPP,R	ABS	1	
4	DA97-00585B	ASSY HINGE-UPP,L		1	
4-1	DA61-00051E	HINGE-UPP,L	SHP1 , T3.0	1	
4-2	DA97-01497A	ASSY-SHIM HINGE UPP	RD-PVC	1	
5	DA97-00586B	ASSY HINGE-UPP,R		1	
5-1	DA61-00052G	HINGE-UPP,R	SHP1 , T3.0	1	
5-2	DA97-01497A	ASSY-SHIM HINGE UPP	RD-PVC	1	
6	DA60-10124A	SCREW-TAP TITE	M6 ,L16,HH,ZPC2	6	
7	6002-000215	SCREW-TAPPING	TH,+,1,M4.0,L16,ZPC(YEL)	2	
8	DA97-00165G	ASSY HINGE-LOW,L	T4.5 , SHP1	1	
8-1	6003-001435	SCREW-TAPTITE	M5,L12.7,ZPC(YEL)	1	
8-2	6011-001442	BOLT-SOCKET	M8,L15,ZPC(BLK),SCM435	1	
8-3	6021-001125	NUT-HEXAGON	3,M8, P1.25,ZPC(BLK),SWRCH10	1	
8-4	DA61-00096J	HINGE-LOW,L	SHP1 , SM45	1	
8-5	DA66-90113B	CAM HINGE-RISER,UPP	NY-66(2110R)	1	
8-6	DA97-01494A	ASSY-SHIM HINGE LOW	T1.5 , RD-PVC	1	
9	DA97-00166E	ASSY HINGE-LOW,R	T4.5 , SHP1	1	
9-1	6003-001435	SCREW-TAPTITE	M5,L12.7,ZPC(YEL)	1	
9-2	6011-001442	BOLT-SOCKET	M8,L15,ZPC(BLK),SCM435	1	
9-3	6021-001125	NUT-HEXAGON	3,M8, P1.25,ZPC(BLK),SWRCH10	1	
9-4	DA61-00095G	HINGE-LOW, R	SHP1 , SM45	1	
9-5	DA66-90113B	CAM HINGE-RISER,UPP	NY-66(2110R)	1	
9-6	DA97-01494A	ASSY-SHIM HINGE LOW	T1.5 , RD-PVC	1	
10	DA61-00317A	BRACKET-HINGE,LOW	SHP1	2	
11	6009-001255	SCREW-HEX	SWRCH18A,-,HEX-PLANGE,HEX,	M6,L 8	
12	DA61-30102C	FOOT-FRONT	PP	2	
13	DA61-00056A	CASTER-FRONT ASSY	SCP1	2	
13-1	DA60-90124A	RIVET	MSWR10,OD6.0,L56,ZPC3	1	
13-2	DA61-40115A	CASTER-FRONT	NY-66	1	
13-3	DA71-00064A	REINF-CASTER-FRONT	SCP1 , T2.6	1	
14	DA63-00189B	COVER-LEG-FRONT	HIPP	1	
15	DA97-01283A	ASSY SUPPORT-CIRCUIT MOTOR	MOTOR	1	
15-1	DA61-00415A	SUPPORT-CIRCUITE MOTOR	ABS SCRAP	1	
15-2	DA31-00020H	MOTOR DC-BLDC	DRCP3030LA , 0.259A	1	
15-3	DA63-01146A	GROMMET-MOTOR	NBR	2	
15-4	DA63-00713A	COVER-MOTOR	PP	1	
15-5	DA96-00042A	ASSY-HARNESS COMP	350mm	1	
15-6	6501-000122	CABLE TIE	DACT-100,-,W2.5,L101.6,NTR	1	
15-7	6002-000480	SCREW-TAPPING	M4,L10,ZPC(YEL)	1	
16	DA97-00555B	ASSY CHASSIS-COMP		1	
16-1	DA71-00058A	CHASSIS-COMP	SBHG1 , T1.4	1	
16-2	DA61-40126B	CASTER-REAR	PP	2	
16-3	DA60-90146A	PIN-CASTER	MSWR10,OD6.0,L40,ZPC2	2	
17	DA97-01285A	ASSY TRAY-DRAIN WATER		1	
17-1	DA66-00034A	TRAY-DRAIN WATER		1	
17-2	6009-001252	SCREW-SPECIAL	SWRCH18A,-,PH,+,M4.0,L20	4	
17-3	DA97-00259E	ASSY PIPE-SPIRAL COND	SPIRAL	1	

# Illustrated Parts Catalog.

## ■ Parts List of Unit Exploded View

NO	CODE-NO	PART NAME	Spec	Quantity	Remark
17-4	DA63-40128A	GROMMET-SUB COND	NBR	2	
17-5	DA62-00440A	SEAL-SUB COND	FOAM-PE , T5.0	1	
18	DA31-00010C	FAN-ASSY	_150	1	
18-1	DA31-00015B	FAN-TURBO	ABS	1	
18-2	DA61-20128A	SPRING ETC-FAN	STS27 , PI7.8, ID1.0	1	
19	MK4A5QR1U/E/Ø1	COMPRESSOR	15.31cc,220/240V~50Hz,RSCR	1	
20	DA73-30102B	DRYER-ASSY	CU,OD18.85,ID2,L102,10.0G	1	
21	DA63-40004A	GROMMET-COMP	NBR	4	
22	DA34-10003V	RELAY PROTECTOR O/L	4TM265RHBY-53,	1	
23	DA35-10013B	RELAY-PTC	J531Q35E330M385-2,385V.6A	1	
24	DA63-10352A	COVER-RELAY	PP	1	
25	DA39-00084B	WIRE HARNESS COMP	-,EXP,;,;,COMP,NOTHING,	1	
26	DA60-20008A	BOLT-HEX	SM30C	4	
27	DA97-00918A	ASSY PIPE CONNECT		1	
28	DA97-00359A	ASSY TUBE-DRAIN	SOFT-PVC , T1.0 , L21	1	
28-1	DA62-20001R	TUBE PVC	SOFT-PVC , T1.0 , L21	1	
28-2	DA63-00951C	GROMMET-DRAIN HOSE	NBR	1	
29	DA62-20001P	TUBE PVC	SOFT-PVC , T1.0 , L21	1	
30	DA63-00278E	COVER COMP-ASSY	SBHG1 , T0.35	1	
31	DA61-00261A	CASE PCB-PANEL	ABS	1	
32	DA63-00783A	COVER PCB-PANEL	ABS	1	
33	DA41-00185B	PBA MAIN	ET-R600a-,FR-4,1.6T*163*197,D	1	Production Month ( ~ March. 2004)
33	DA41-00185A	PBA MAIN	ET-R600a-,FR-4,1.6T*163*197,D	1	
33	DA41-00185J	PBA MAIN	ET-R600a-,FR-4,1.6T*163*197,D	1	Production Month (April. 2004 ~)
33	DA41-00185K	PBA MAIN	ET-R600a-,FR-4,1.6T*163*197,D	1	
34	DA27-00002A	COIL	4,+50%,-30%,38*50	1	
35	2501-001186	C-OIL	5UF,350V,BK,43X55MM,15	1	
36	DA71-00155B	FIXER-MAIN PCB	RD-PVC , T1.5	1	
37	DA74-00038C	DUCT-CABI,C	ABS SCRAP	1	
38	DA74-40149C	VALVE WATER-ASSY	RIV-12A-4	1	
40	DA73-00070V	PIPE-WATER LINE	PB(4137) , Ø6.35	1	
41	DA60-30104A	NUT-WATER LINE	NY-6	1	
42	DA71-20208A	FIXER-VALVE WATER	NY-6	1	
43	DA73-00134A	PIPE-WATER FRE,ASSY(SUB)	SUBJAL , Ø1.0	1	
44	DA72-00228C	SEAL-WATER PIPE	FOAM-PE , T10 , L80	1	
45	DA97-00979A	ASSY COVER-PIPE WATER	240V , 7W	1	
46	DA63-01701A	GROMMET-TUBE WATER,FILL	IN SILICON	1	
47	DA47-00035A	HEATER-WATER,PIPE	240V , 7W	1	

# 12 . Illustrated Parts Catalog.

## 12-5) Freezer Room Exploded View (RS21D, RS21F, RS21J, RS21K, RS23D, RS23F, RS23J, RS23K)

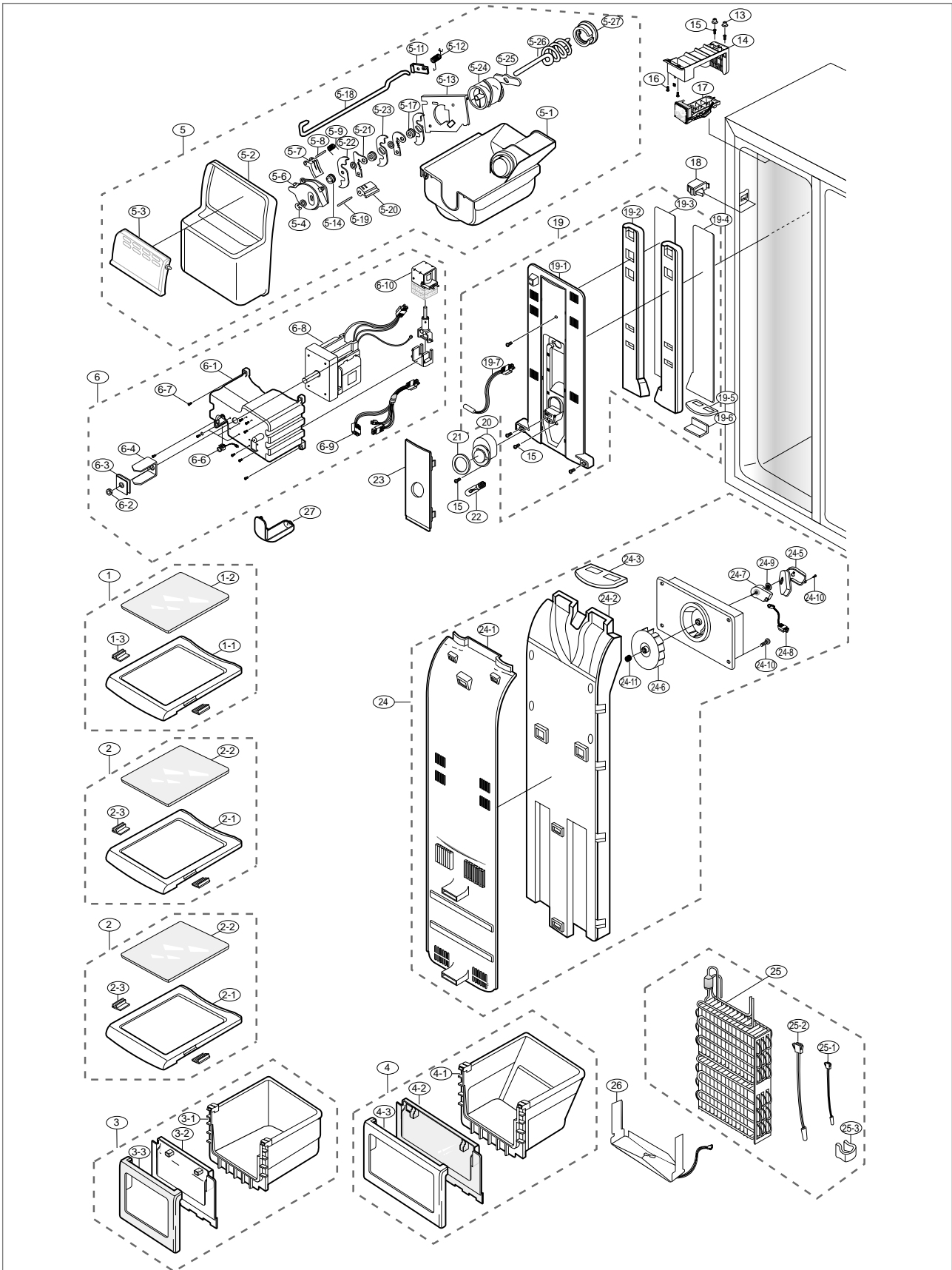

## Illustrated Parts Catalog.

### ■ Part List of Freezer Room

NO	CODE-NO	PART NAME	Spec	Quantity	Remark
1	DA67-00180A	SHELF-FRE ASSY	GLASS-SHELF	1	
1-1	DA67-00175A	SHELF-FRE	HIPS	1	
1-2	DA67-00177B	SHELF GLASS	GLASS	1	
1-3	DA64-00090A	TRIM-SHELF	PVC	2	
2	DA67-00181A	SHELF-FRE ASSY	GLASS-SHELF	1	
2-1	DA67-00146A	SHELF-FRE	HIPS	1	
2-2	DA67-00177C	SHELF GLASS	GLASS	1	
2-3	DA64-00090A	TRIM-SHELF	PVC	2	
3	DA67-00182C	CASE-BASKET UPP ASSY		1	
3-1	DA67-00150A	CASE-BASKET	HIPS	1	
3-2	DA63-00174C	COVER-FRONT FRE,B	HIPS	1	
3-3	DA63-00170A	COVER-FRONT	HIPS	1	
4	DA67-00183C	CASE-BASKET LOW ASSY		1	
4-1	DA67-00151A	CASE-BASKET	HIPS	1	
4-2	DA63-00174C	COVER-FRONT FRE,B	HIPS	1	
4-3	DA63-00170A	COVER-FRONT	HIPS	1	
5	DA59-00136E	CRUSHER ICE ASSY		1	
5-4	DA60-40116A	WASHER-PLAIN	STS4	1	
5-2	DA63-00180A	COVER-ICE BUCKET	PP	1	
5-3	DA63-00181B	COVER-ICE BUCKET,B	GPPS	1	
5-5	DA63-10016A	COVER-CRUSHER DISP	PC	1	
5-1	DA66-00033A	TRAY-ICE		1	
6	DA61-00143C	CASE-AUGER MOTOR,ASSY		1	
6-1	DA67-00144B	CASE-AUGUR MOTOR	ABS SCRAP	1	
6-2	DA61-20140A	SPRING ETC-SOLENOID	STS304	1	
6-3	DA71-00163A	FIXER-NUT	STS420-J2 , T1 , CLIP	1	
6-4	DA70-20017A	PLATE-D/AUGER DISP	STS304 , L127XD14.4	1	
6-5	DA65-20107A	SADDLE-SOLENOID	NY-6	1	
6-6	DA47-40112V	LAMP HOLDER	PBT 5VA , E14	1	
6-7	6001-000033	SCREW-MACHINE	TH,+,M4,L10,-,STS304	2	
6-8	DA31-10141D	MOTOR GEARD	ISG-3250SSD,SR-S6586,1.8A,50	1	
6-9	DA39-00083A	WIRE HARNESS-SUB		1	
6-10	DA74-40151F	VALVE-SOLENOID		1	
6-11	DA63-90008A	BUSH-SOLENOID	POM	1	
13	DA71-20252A	FIXER-GROMMET DOOR	ABS	2	
14	DA59-30103J	ICE MAKER	DC12V	1	
15	6002-000215	SCREW-TAPPING	TH,+,1,M4.0,L16,ZPC(YEL)	15	
16	6002-000471	SCREW-TAPPING	TH,+,1,M4,L12,PASS,STS304	2	
17	DA67-40308A	TRAY-ICE	PP , T1.0	1	
18	DA34-10121A	SWITCH-DOOR	PA6	1	
19	DA97-00101J	ASSY COVER-MULTI FRE		1	
19-1	DA63-00363A	COVER EVAP-FRE,FRONT UPP	PP	1	
19-2	DA72-00245A	INSULATION DUCT-FRE,UPP	FOAM-PS	1	
19-3	DA72-00158F	SEAL EVAP-FRONT FRE,L	T2.0	1	
19-4	DA72-00159E	SEAL EVAP-FRONT,FRE R	T2.0	1	
19-5	DA62-00219A	SEAL-AIR FRE,UPP	OJC-3000 , T7.0	1	
19-6	DA70-00215B	PLATE-INS,DUCT	RD-PVC , T1.2	2	
19-7	DA32-10105H	SENSOR-ASSY	502AT,K-PJT,-10-35,5V,5KOHM	1	
20	DA63-00178A	COVER-SENSOR	GPPS	2	



# 12 . Illustrated Parts Catalog.

## 12-6) Freezer Room Door Exploded View

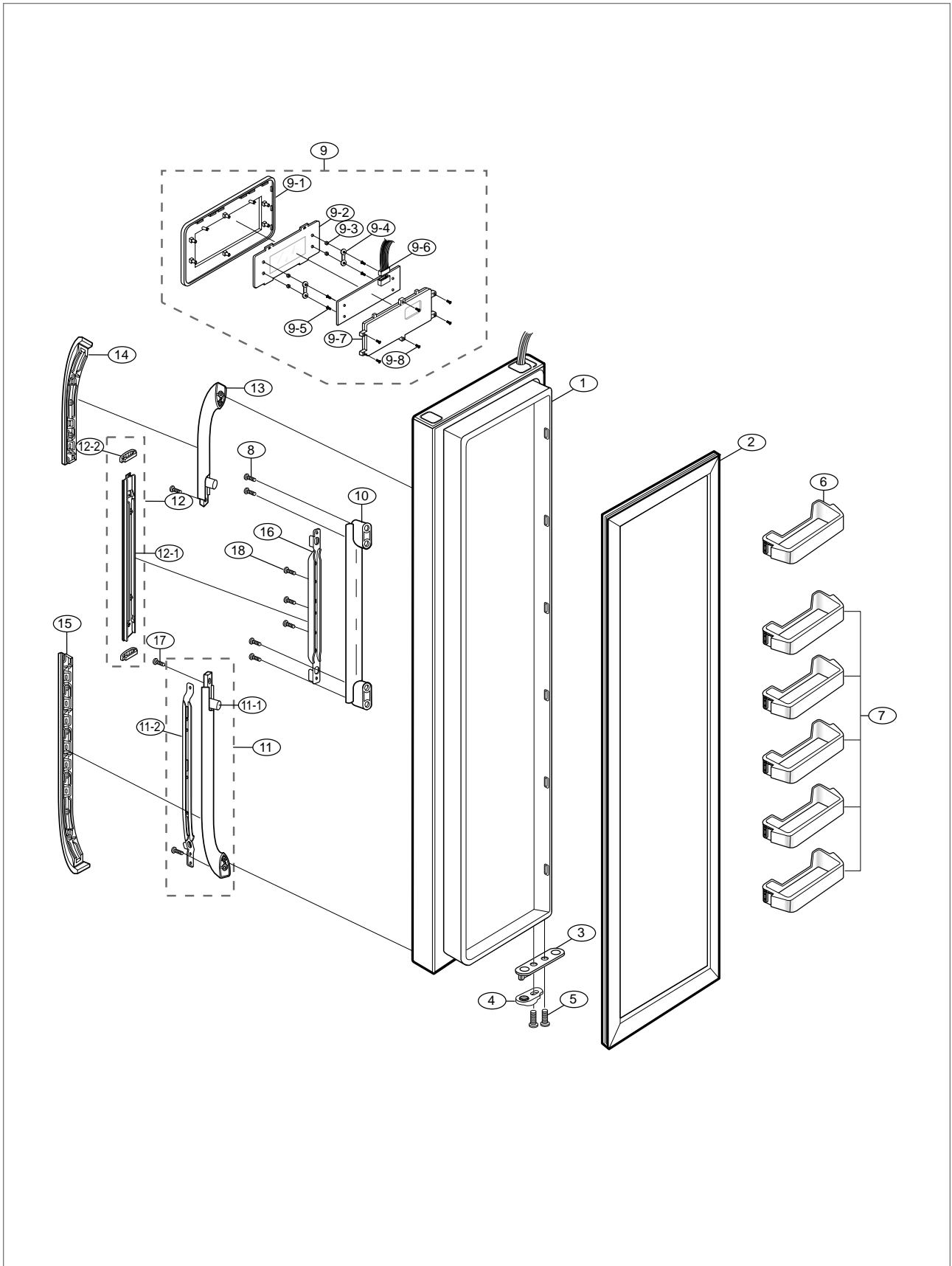





# 12 . Illustrated Parts Catalog.

## 12-7) Freezer Room Door Exploded View (RS21D, RS21F, RS21J, RS21K, RS23D, RS23F, RS23J, RS23K)

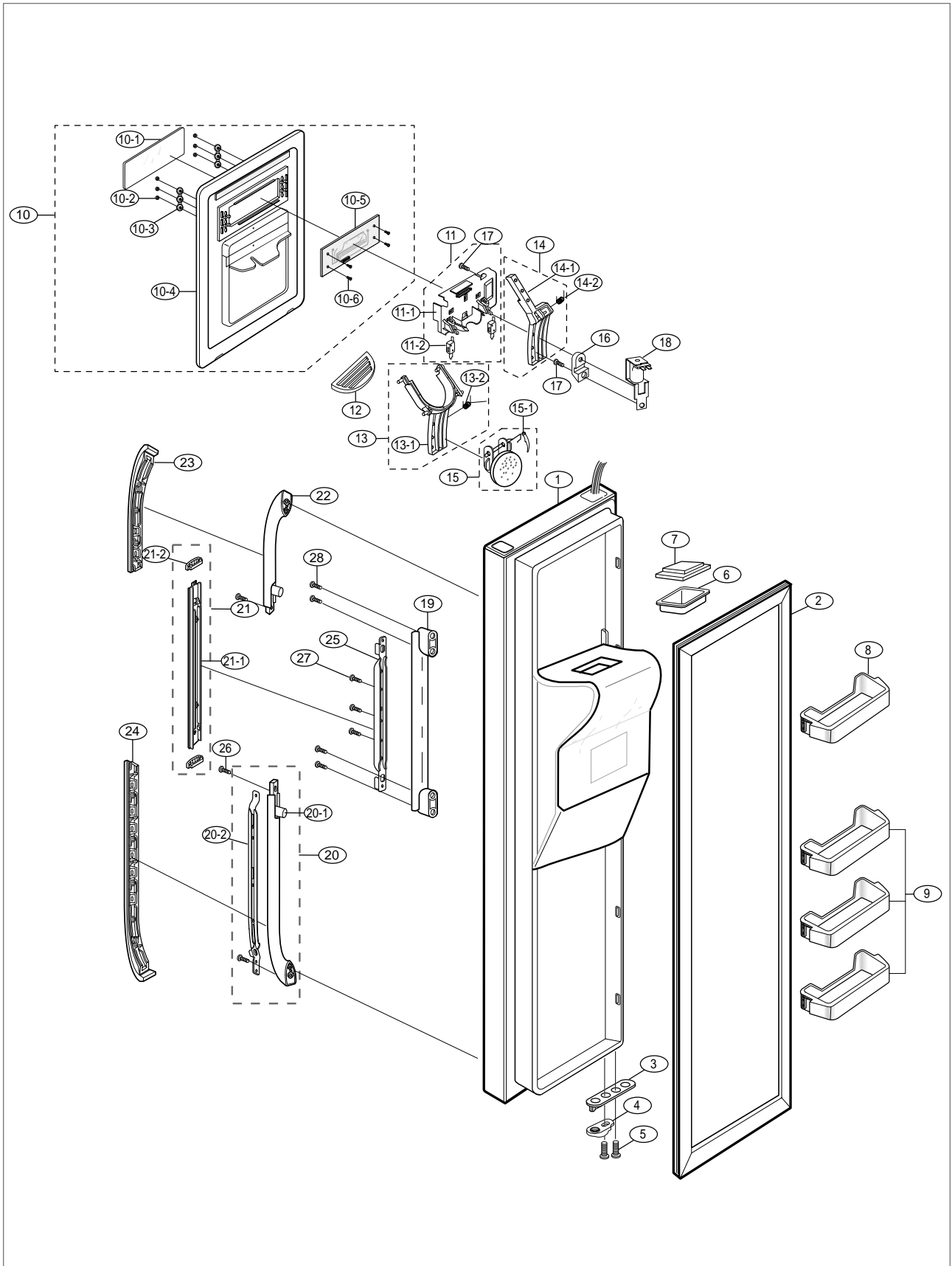

# Illustrated Parts Catalog.

## ■ Part List of Freezer Room Door Exploded View

NO	CODE-NO	PART NAME	Spec	Quantity	Remark
1	-	ASSY DOOR FOAM FRE	SNOW WHITE	1	
2	DA63-30231K	GASKET DOOR-FRE ASSY	SF-PVC	1	
3	DA61-00776A	STOPPER DOOR	SHP1,T3.0	1	
4	DA66-90112C	CAM HINGE-RISER,LOW	NY-66(2110R)	1	
5	6002-000468	SCREW-TAPPING	PH,+2S,M5.0,L18,ZPC(YEL),	4	
6	DA67-00163B	CAP-CHUTE,ICE	ABS , SNOW-WHITE	1	
7	DA72-00262A	CUSHION-GUIDE ICE CHUTE	SILICON	1	
8	DA63-00213C	GUARD-FRE,UPP	HI-PP	1	
9	DA63-01311A	GUARD BOTTLE-FRE LOW	HI-PP	3	
10	DA97-01345A	ASSY COVER-DISPENSER	SNOW-WHIT	1	
10-1	DA63-01608A	COVER DISPENSER	ABS , SNOW-WHITE	1	
10-2	DA64-00740B	KNOB-TOUCH	ABS , SILVER COLOR	6	
10-3	DA61-00874A	SUPPORT-KNOB TOUCH,DISP	SILICON	2	
10-4	DA63-01169H	COVER-CONTROL DISP	ABS , SNOW-WHITE	1	
10-5	DA41-00173B	PBA PANEL	10mm	1	
10-6	6002-000466	SCREW-TAPPING	PH,2S,M3.0,L8,ZPC(YEL)	4	
11	DA97-01346A	ASSY COVER-PCB,PANEL REAR	REAR ,SNOW	1	
11-1	DA63-01609A	COVER-PCB PANEL,REAR	PP,SNOW WHITE	1	
11-2	DA34-00011A	SWITCH-MICRO	VP533A-OF-5,MICRO,250V,15A,	2	
12	DA66-00037G	TRAY DISPENSER	HIPS,SNOW-WHITE	1	
13	DA97-01350A	ASSY LEVER-DISPENSER,ICE	SNOW-WHITE	1	
13-1	DA66-00236A	LEVER-DISPENSER,ICE	ABS , SNOW-WHITE	1	
13-2	DA61-00088A	SPRING ETC-DISPENSER ICE-LEVER	STS304,	1	
14	DA97-01352A	ASSY LEVER-DISPENSER,WATER	SNOW-WHITE	1	
14-1	DA66-00237A	LEVER-DISPENSER WATER	ABS , SNOW-WHITE	1	
14-2	DA61-00338A	SPRING ETC-WATER LEVER,DISP	STS304	1	
15	DA97-00283A	ASSY COVER-ICE ROUTE	SNOW-WHITE	1	
15-1	DA71-00073A	STOPPER-LEVER DISPENSER	POM	1	
16	DA61-70234A	SUPPORT-TIME DELAY	HIPS	1	
17	6002-000471	SCREW-TAPPING	TH,+1,M4,L12,STS304,	1	
18	DA74-40154C	VALVE SOLENOID	USD-DPS4	1	
19	DA64-00096B	HANDLE BASE-MID	HIPP , SNOW-WHITE	1	
20	DA64-00111B	HANDLE-LOW,ASSY	SNOW-WHITE	1	
20-1	DA64-00095B	HANDLE BASE-LOW	HIPP , SNOW-WHITE	1	
20-2	DA71-00078A	REINF-HANDLE,LOW	SBHG1,T1.4	1	
21	DA64-00209A	HANDLE TRIM-ASSY,MID	ABS , SNOW-WHITE	1	
21-1	DA64-00098B	HANDLE TRIM-MID	ABS , SNOW-WHITE	1	
21-2	DA64-00196A	TRIM-HANDLE CONNECT,MID	SILVER COLOR	2	
22	DA64-00097B	HANDLE-BASE,UPP	HIPP , SNOW-WHITE	1	
23	DA64-00100E	HANDLE-TRIM,UPP	ABS , SNOW-WHITE	1	
24	DA64-00099B	HANDLE-TRIM,LOW	ABS , SNOW-WHITE	1	
25	DA71-00077A	REINF-HANDLE,MID	SBHG1,T1.4	1	
26	6002-000213	SCREW-TAPPING	TH,+1,M4,L12,ZPC(YEL),SWR	3	
27	6002-000470	SCREW-TAPPING	TH,+1,M4,L10,ZPC,SCRCH18A	3	
28	6002-000468	SCREW-TAPPING	PH,+2S,M5.0,L18,ZPC(YEL),	4	

12 . Illustrated Parts Catalog.

12-8) Refrigerator Room Door Exploded View

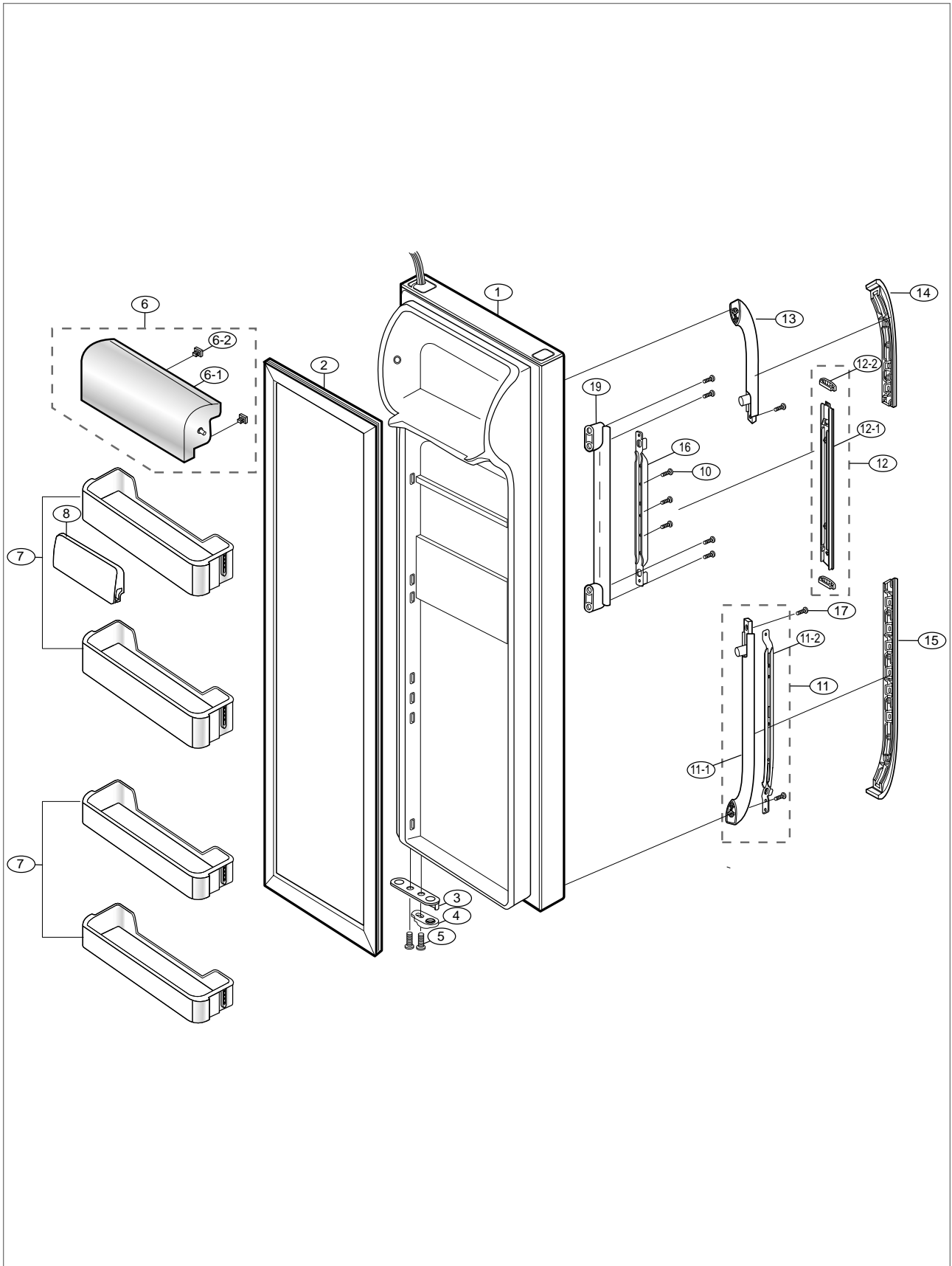



# 12 . Illustrated Parts Catalog.

## 12-9) Refrigerator Room Door Exploded View (RS21H, RS21F, RS21K, RS23H, RS23F, RS23K)

